

SPICER®



Spicer Life Series® SPL® 170® and SPL® 250®

Service-Free* U-Joints

**No Relubrication.
Lower Overall Costs.
More Time on the Road.**

Spicer Life Series® (SPL®) is the name professionals trust to deliver the highest performance for their heavy-duty vehicles. With SPL service-free* universal joint kits, you can lower your overall operational costs by eliminating the need for lubrication over the life of the u-joint (see chart on back). Get the original equipment quality that you expect from SPL 170 and SPL 250 u-joints, plus the reliability that service-free* options can deliver for you.

* Inspections must be performed at each maintenance interval to check for wear, damage or looseness that could affect lubricant life and lead to driveline failure.



Spicer Life Series® (SPL®) Service-Free* U-Joints

SPL® 170® and SPL® 250®—Permanently Lubricated for Lower Operating Costs.

The Spicer Life Series® (SPL®) brand delivers the same premium performance as original equipment parts—because they *are* original equipment parts. Engineered to meet the latest specifications and reflect the most forward-thinking advancements, SPL parts go above and beyond to outperform the competition. You get the durability and dependability you expect from the most trusted name in universal joints.

SPL® Service-Free* Universal Joint Kits are lubricated for the life of the u-joint, so you keep your overall operational costs low over time. The service-free* options for the SPL 170 (SPL170-SF4X) and SPL 250 (SPL250-SF3X) kits are ideal for heavy-haul applications and are capable of meeting the requirements of future fast axle ratios. Higher upfront costs are more than offset by lower operating costs over the life of the driveshaft.** See charts to the right.

**Upfront cost estimates are based on installing 2 u-joints in an existing driveshaft. One hour of labor @ \$90/hour. Maintenance expense is estimated using 4 lubrications per year @ \$23.60 (material + labor).

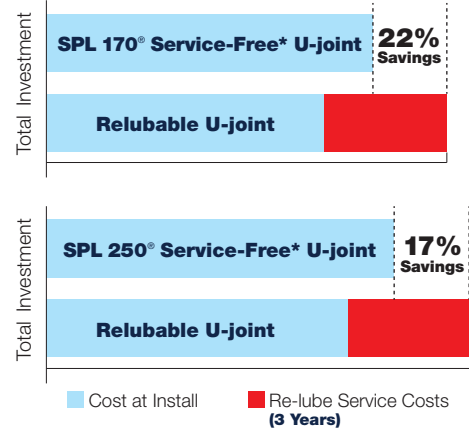

Check Out the Advantages Only Spicer Delivers!

New Thrust Washer

- Improves lubrication
- Eliminates friction/heat
- Extends life

New Bearing Package

- Larger rollers
- 40% increase in bearing capacity

New Spicer™ Ultra-Premium Synthetic Grease

- Significantly extends life

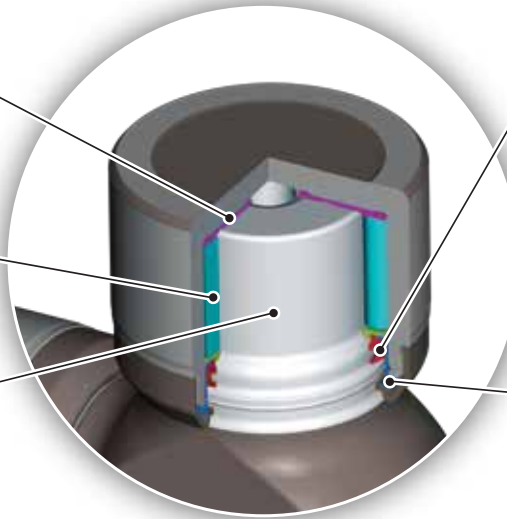

New Multi-Lip Seal

- Viton® material
- Extends life
- Improves wear capabilities
- Improves heat resistance
- Optimizes lube retention
- Provides added protection against external contaminants

New Seal Guard

- Provides protection from external contaminants



Kits include Spicer® Ultra-Premium Synthetic Grease packet for pre-lube.

Compatible with all NLGI-2 greases, Spicer® ultra-premium synthetic grease delivers professional-grade quality—even at high temperatures. For more information about our Spicer® ultra-premium synthetic grease, please visit our website at www.SpicerParts.com/grease.

Discover the difference that SPL service-free* universal joints can make for your vehicle. Talk to your Spicer parts representative or visit www.SpicerParts.com/u-joints today!



Dana Aftermarket Group
PO Box 321 Toledo, Ohio 43697-0321
Phone: 1.800.621.8084
www.SpicerParts.com

Form # J3342-SPLHDSF-62014
Copyright Dana Limited, 2014.
All rights reserved. Dana Limited.
Printed in U.S.A.

SPICER®



* Inspections must be performed at each maintenance interval to check for wear, damage or looseness that could affect lubricant life and lead to driveline failure. Viton® is a registered trademark of E. I. du Pont de Nemours and Company or its affiliates.

