

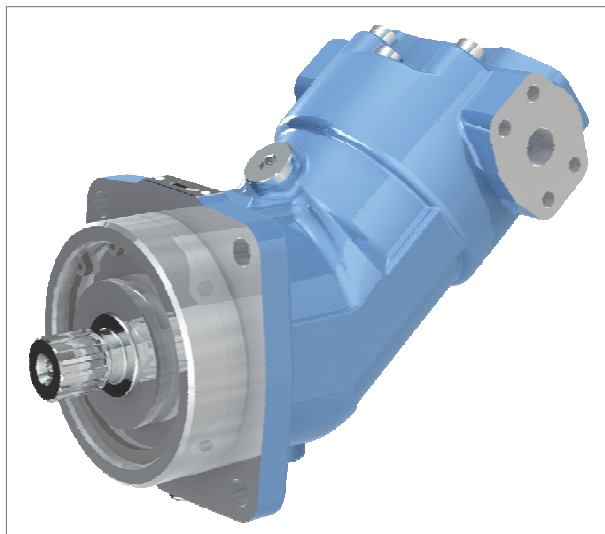

**BREVINI<sup>®</sup>**

*Motion Systems*



**SH11C**

***MOTORI A CILINDRATA FISSA***

**FIXED DISPLACEMENT MOTORS**

## DESCRIZIONE - CARATTERISTICHE GENERAL INFORMATION - FEATURES

*I motori SH11C sono a pistoni assiali, a corpo inclinato, a cilindrata fissa, progettati per operare sia in circuito chiuso che in circuito aperto. Il distributore a superficie sferica, l'accurata lavorazione e l'alta qualità dei materiali e dei componenti usati, consentono ai motori SH11C di lavorare fino a 430 bar in continuo e di sopportare picchi di 480 bar. Provat in laboratorio e sperimentati sul campo queste unità hanno dimostrato una lunga durata di esercizio con elevati rendimenti. Il supporto dell'albero, realizzato mediante cuscinetti a rotolamento, è dimensionato in modo da sopportare elevati carichi assiali e radiali. La versatilità dei motori SH11C, comprendente vari coperchi, alberi di uscita e valvole flangiabili, consente a queste unità di essere idonee alle diverse tipologie di impianto, sia nel settore mobile che in quello industriale. I motori SH11C sono disponibili in versione ISO e in versione SAE.*

SH11C motors are a family of fixed displacement, bent axis piston design for operation in both open and closed circuit. The proven design incorporating the lens shape valve plate, the high quality components and manufacturing techniques make the SH11C motors to able provide up to 430 bar [6235 psi] continuous and 480 bar [6960 psi] peak performance. Fully laboratory tested and field proven, these units provide maximum efficiency and longlife. Heavy duty bearings permit high radial and axial loads.

Versatile design includes a variety of port plate, shaft end and valves package that will be fit the SH11C motors to any application both industrial and mobile. SH11C motors are available in both ISO and SAE version.

## Fluidi:

Utilizzare fluidi a base minerale con additivi anticorrosione, antiossidanti e antiusura (HL o HM) con viscosità alla temperatura di esercizio di  $15 \pm 40$  cSt. Una viscosità limite di 800 cSt è ammissibile solo per brevi periodi in Condizione di partenza a freddo, per valori superiori contattare Dana Brevini. Non sono ammesse viscosità inferiori ai 10 cSt. Viscosità comprese tra i 10 e i 15 cSt sono tollerate solo in casi eccezionali e per brevi periodi.

## Temperature:

Non è ammesso il funzionamento dell'unità a pistoni con temperature del fluido idraulico superiori a  $115^{\circ}\text{C}$  e inferiori a  $-25^{\circ}\text{C}$ . Per applicazioni con temperature inferiori contattare Dana Brevini.

## Filtrazione:

Una corretta filtrazione contribuisce a prolungare la durata in esercizio dell'unità a pistoni. Per un corretto impiego dell'unità a pistoni la classe di contaminazione massima ammessa è 21/19/16 secondo la ISO 4406:1999.

## Pressione di esercizio:

La pressione massima ammissibile sulle bocche in pressione è 430 bar continui e 480 bar di picco. Nel caso di due motori collegati in serie limitare la pressione di esercizio totale  $P1+P2$  a 700 bar massimi.

## Hydraulic fluids:

Use fluids with mineral oil basis and anticorrosive, antioxidant and wear preventing addition agents (HL or HM). Viscosity range at operating temperature must be of  $15 \pm 40$  cSt. For short periods and upon cold start, a max. viscosity of 800 cSt is allowed, for different types of viscosity please contact Dana Brevini. Viscosities less than 10 cSt are not allowed. A viscosity range of  $10 \pm 15$  cSt is allowed for extreme operating conditions and for short periods only.

## Temperature ranges:

The operating temperature of the oil must be within  $-25^{\circ}\text{C} \div 115^{\circ}\text{C}$  [ $-13^{\circ}\text{F} \div 239^{\circ}\text{F}$ ]. For applications with lower temperatures please contact Dana Brevini.

## Filtering:

A correct filtering is essential for long and satisfactory life of axial piston units. In order to ensure a correct functioning of the unit, the max. permissible contamination class is 21/19/16 according to ISO 4406:1999.

## Operating pressure:

The maximum permissible pressure on pressure ports is 430 bar [6235 psi] continuous and 480 bar [6960 psi] peak. If two motors are connected in series, total working pressure  $P1+P2$  has to be limited 700 bar max. [10150 psi].

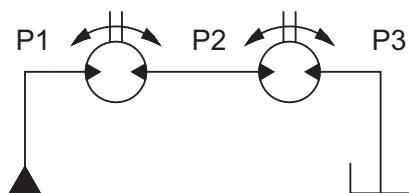

## Pressione in carcassa:

La pressione massima ammissibile in carcassa è di 10 bar. Una pressione superiore può compromettere la durata e la funzionalità della guarnizione dell'albero di uscita.

## Case drain pressure:

Maximum permissible case drain pressure is 10 bar [145 psi]. A higher pressure can damage the main shaft seal or reduce its life.

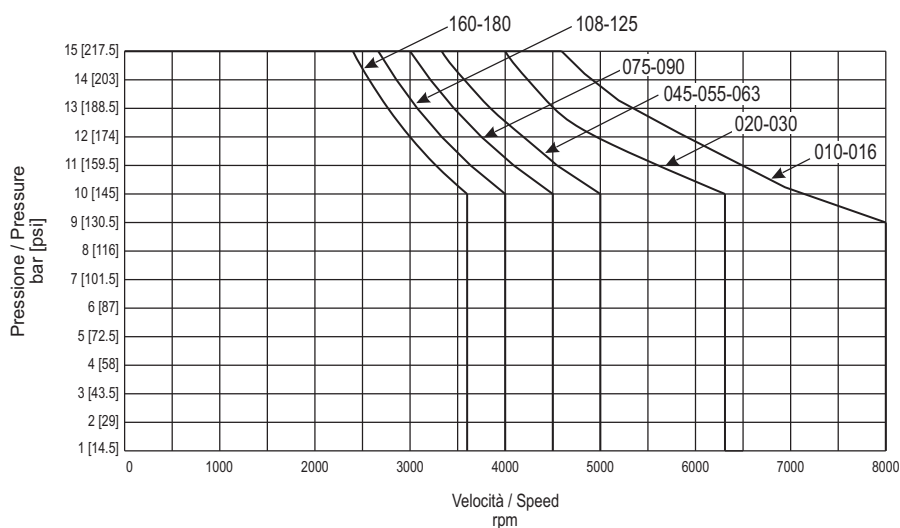

### Albero di uscita:

La tabella è una guida per la determinazione dei carichi accettabili. I valori sono determinati in modo da garantire una vita almeno pari all'80% della vita dei cuscinetti in assenza di carico esterno. I valori sono riferiti a carichi applicati nella mezzeria dell'albero e nella direzione più sfavorevole.

### Output shaft:

Table is a guide to determine max. permissible loads. Values are calculated in such a way to assure at least 80% of the bearing operating life where no external load is applied. The published values are related to loads applied in the middle of shaft and in the least favourable direction.

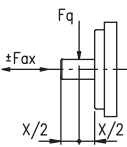
Cilindrata / Displacement			010*	016*	020	030	045*	055	063	075	090	108	125	160	180	
	Forza radiale Radial load ( $F_{q \max}$ )	N [lbf]	3000 [674.4]	3200 [719.4]	4300 [967.5]	6100 [1372.5]	8350 [1877.2]	9200 <sup>(1)</sup> [2068]	10300 <sup>(1)</sup> [2317.5]	11500 <sup>(1)</sup> [2587.5]	12900 <sup>(1)</sup> [2902.5]	13600 <sup>(1)</sup> [3060]	15900 <sup>(1)</sup> [3577.5]	18400 <sup>(1)</sup> [4140]	20600 <sup>(1)</sup> [4635]	
	Carico Load	N/bar [lbf/psi]	8.5 [0.128]	9 [0.135]	12 [0.18]	19 [0.285]	23.8 [0.357]	25 [0.375]	30 [0.45]	25.7 [0.386]	28.5 [0.428]	35 [0.525]	37 [0.555]	41 [0.615]	45 [0.675]	
	Forza assiale tirante Axial pulling load ( $F_{ax \max}$ )	N [lbf]	250 bar [3625 psi]	550 [123.6]	850 [191.1]	1000 [225]	1300 [292.5]	1740 [391.2]	1920 [432]	2150 [484]	2300 [517.5]	2800 [630]	2900 [652.5]	3300 [742.5]	3800 [855]	4050 [911.2]
		N/bar [lbf/psi]	350 bar [5075 psi]	800 [179.8]	1050 [236.0]	1300 [292.5]	1800 [405]	2400 [539.5]	2650 [596]	2990 [673]	3550 [798.75]	3800 [855]	4050 [911.25]	4550 [1023.7]	5300 [1192.5]	5800 [1305]
Forza assiale spingente Axial pushing load ( $F_{ax \max}$ )	N [lbf]	< 100 bar [< 1450 psi]	320 [71.9]	320 [71.9]	500 [112.5]	500 [112.5]	800 [179.8]	800 [180]	800 [180]	1000 [225]	1000 [225]	1250 [281.25]	1250 [281.25]	1600 [360]	1600 [360]	
	N/bar [lbf/psi]	> 100 bar [> 1450 psi]	3 [0.045]	3 [0.045]	5 [0.075]	5 [0.075]	8.7 [0.131]	9 [0.135]	9 [0.135]	12 [0.18]	12 [0.18]	13 [0.195]	13 [0.195]	17 [0.255]	17 [0.255]	

\* In fase di completamento - Work in progress

(1)

Massima forza radiale permessa per albero SAI (SH11C 055-063):

$F_{q \max} = 6500 \text{ N}$

Massima forza radiale permessa per albero SAM (SH11C 075-090):

$F_{q \max} = 6500 \text{ N}$

Massima forza radiale permessa per albero SAO (SH11C 108-125):

$F_{q \max} = 6500 \text{ N}$

Massima forza radiale permessa per albero SAP (SH11C 160-180):

$F_{q \max} = 6500 \text{ N}$

(1)

Max permissible radial force with SAI shaft (SH11C 055-063):

$F_{q \max} = 6500 \text{ N}$  [1462.5 lbf]

Max permissible radial force with SAM shaft (SH11C 075-090):

$F_{q \max} = 6500 \text{ N}$  [1462.5 lbf]

Max permissible radial force with SAO shaft (SH11C 108-125):

$F_{q \max} = 6500 \text{ N}$  [1462.5 lbf]

Max permissible radial force with SAP shaft (SH11C 160-180):

$F_{q \max} = 6500 \text{ N}$  [1462.5 lbf]

Quando un carico radiale esterno è applicato all'albero la vita dei cuscinetti è determinata dalla intensità, dalla posizione e dalla direzione della forza applicata. Il diagramma mostra come la vita dei cuscinetti varia con la direzione del carico. Nel diagramma il valore 100% rappresenta la vita dei cuscinetti in assenza di carico esterno. La direzione ottimale del carico dipende dalla bocca dell'unità a pistoni in pressione.

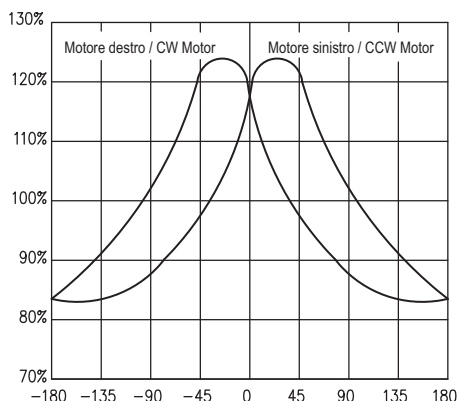

Il diagramma mostra che per determinate direzioni di carico è possibile avere incrementi di durata della vita dei cuscinetti anche del 30%. L'aumento massimo di durata dipende dalla pressione di esercizio e dalla dimensione nominale dell'unità a pistoni.

Nel considerare la forza assiale permessa bisogna fare attenzione alla direzione di trasferimento della forza:

- Carichi assiali spingenti incrementano la vita dei cuscinetti.
- Carichi assiali tiranti riducono la vita dei cuscinetti (se possibile i carichi tiranti devono essere evitati).

When an external side (radial) load is applied to the drive shaft, the bearing life will vary accordingly to the magnitude, location and direction of the load. The diagram shows how the bearing operating life varies versus the direction of the load. In the diagram 100% represents the bearing operating life where no external side load is applied to the drive shaft. The

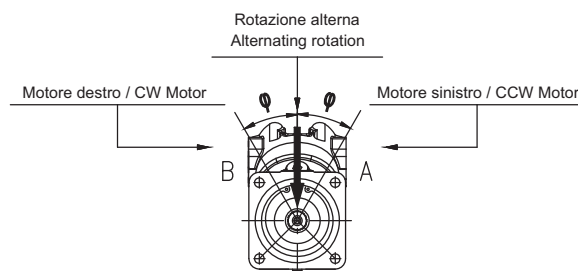

The bearing operating life increases up to 30% when the load is applied with some peculiar directions and the maximum increase is dependent on the operating pressure and the nominal size of the unit.

When considering the permissible axial force, the force - transfer direction must be taken in account:

- Pushing axial loads increase the bearing life.
- Pulling axial loads reduce the bearing life (if possible pulling axial loads should be avoided).

**Guarnizioni:**

Le guarnizioni utilizzate sulle unità a pistoni assiali SH11C sono in FKM (Fluoroelastomer). Nel caso di impiego di fluidi speciali contattare Dana Brevini.

**Regime minimo di rotazione:**

Nessun limite minimo di velocità; se richiesta l'uniformità di rotazione, la velocità minima non può essere minore di 50 rpm. Per applicazioni particolari contattare la Dana Brevini.

**Installazione:**

I motori possono essere installati in qualsiasi direzione e posizione. Queste unità a pistoni hanno le bocche separate dalla carcassa e devono essere obbligatoriamente drenate. Per maggiori dettagli consultare nel Catalogo Informazioni Generali la sezione "Norme generali di installazione".

**Valvole flangiabili:**

Le valvole sono disponibili per i motori sia in circuito aperto sia chiuso. Per maggiori informazioni consultare il catalogo Valvole Assiali.

**Valvole di lavaggio:**

I motori possono essere forniti con la valvola di lavaggio. Per il montaggio diretto della valvola di lavaggio sui motori è necessario utilizzare un coperchio speciale. Per maggiori informazioni consultare il catalogo Valvole Assiali.

**Relazione tra senso di rotazione e direzione di flusso:**

La relazione tra il senso di rotazione dell'albero dell'unità a pistoni SH11C e la direzione del flusso del fluido è illustrata in figura.

**Seals:**

Seals used on SH11C series are of FKM (Fluoroelastomer). In case of use of special fluids, contact Dana Brevini.

**Minimum rotating speed:**

No limit to Minimum speed; if uniformity of rotation is required, speed must not be less than 50 rpm. In case of use of special applications, contact Dana Brevini.

**Installation:**

SH11C series motors can be installed in every position or direction. These axial piston units have separate ports and drain chambers and so must be always drained. For further details see on the General Information Catalogue, the section "General installation guidelines".

**Flangeable valves:**

Flangeable valves are available for motors both in open and closed loop. For more information see the catalogue Axial Valves.

**Flushing valves:**

The motors can be equipped with flushing valves. The mount the flushing valve on motors, it is necessary to use a special port cover. For more information see the catalogue Axial Valves.

**Relation between direction of rotation and direction of flow:**

The relation between direction of rotation of shaft and direction of flow in SH11C piston units is shown in the picture below.

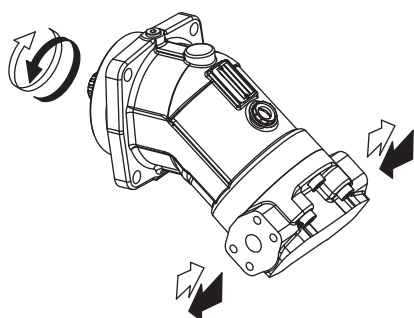

Motore reversibile  
Reversible motor

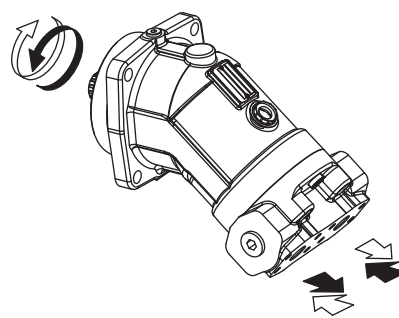

Motore reversibile  
Reversible motor

# SH11C 010-016 MOTORI PER VENTOLE

## SH11C 010-016 FAN MOTORS

I motori SH11C 10-16 cc sono comunemente utilizzati in applicazioni con ventola dove è necessaria una valvola di ritegno integrata con funzione anti-cavitazione.

Il motore per ventole può lavorare in sicurezza ad altissima velocità senza problemi di affidabilità grazie alla valvola anti-cavitazione.

Quando il flusso verso il motore viene interrotto e il motore ruota ad alta velocità, la valvola anti-cavitazione si aprirà e dirigerà il flusso verso la porta di ingresso del motore. Per eseguire questa funzione, è necessario che sia disponibile una sufficiente pressione di ritorno. Se la pressione di ingresso è insufficiente, si verificherà la cavitazione del motore.

Una contropressione, in un circuito aperto, può essere creata da una valvola di contropressione attraverso la linea verso il serbatoio; se possibile, dovrebbe essere pilotato per minimizzare le perdite di potenza. Nella maggior parte delle applicazioni è sufficiente una contropressione di circa  $8 \pm 10$  bar.

### Codice di ordinazione

Con la valvola anti-cavitazione integrata, è necessario specificare il senso di rotazione del motore al momento dell'ordine del motore.

### Tipiche applicazioni

- Scambiatori di calore
- Seminatrici pneumatiche
- Ventilatori

SH11C 10-16 cc motors are common in fan application. Typical need of this application are built-in check valve in anti-cavitation function.

The fan motor can work safely at very high speed without reliability problems thanks to anti-cavitation valve.

When the flow to the motor is shut off and the motor is rotating at high speed, the anti-cavitation valve will open and direct flow to the motor inlet port. To execute this function, it is necessary that sufficient return port back pressure is available. If the inlet pressure is insufficient, motor cavitation will be experienced.

A back pressure, in an open circuit, can be created by a counter pressure valve through the line to the tank; if possible, it should be pilot operated to minimize power losses. A back pressure of about  $8 \pm 10$  bar is sufficient in most applications.

### Ordering code

Due to the built-in anti-cavitation valve, the direction of rotation of the motor must be specified when ordering the motor.

### Typical applications

- Head exchangers
- Air seeders
- Blowers

### Rotazione oraria Clockwise

Coperchio posteriore VMD  
Rear cover VMD

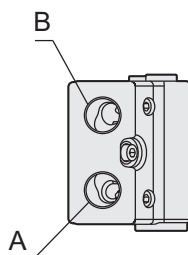
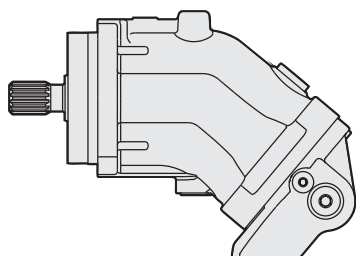

### Rotazione antioraria Counterclockwise

Coperchio posteriore VMS  
Rear cover VMS

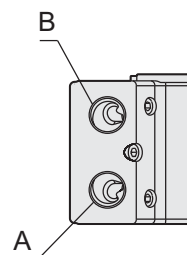

A – B Bocche di alimentazione  
A – B Service ports

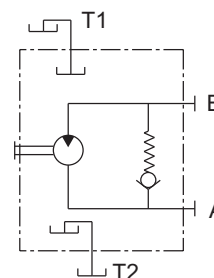
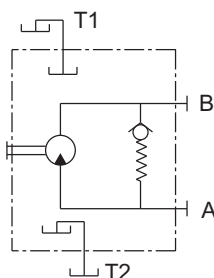

# DATI TECNICI TECHNICAL DATA

Dimensione / Size				010*	016*	020	030	045*	055	063	075	090	108	125	160	180
Cilindrata Displacement		Vg	cm <sup>3</sup> /rev [in <sup>3</sup> /rev]	10.3 [0.626]	16 [0.976]	19.9 [1.213]	31.9 [1.945]	46 [2.807]	56.35 [3.437]	63.26 [3.859]	77.82 [4.747]	86.23 [5.26]	108.4 [6.612]	124.8 [7.613]	163.9 [9.998]	178.1 [10.864]
Pressione max. Max. pressure	cont.	p <sub>nom</sub>	bar [psi]	430 [6235]	430 [6235]	430 [6235]	430 [6235]	430 [6235]	430 [6235]	430 [6235]	430 [6235]	430 [6235]	430 [6235]	430 [6235]	430 [6235]	430 [6235]
	picco peak	p <sub>max</sub>	bar [psi]	480 [6960]	480 [6960]	480 [6960]	480 [6960]	480 [6960]	480 [6960]	480 [6960]	480 [6960]	480 [6960]	480 [6960]	480 [6960]	480 [6960]	480 [6960]
Velocità max. Max. speed		n <sub>0</sub> max	rpm	8000	8000	6300	6300	5600	5000	5000	4500	4500	4000	4000	3600	3600
Portata max. Max. flow		q <sub>max</sub>	l/min [U.S. gpm]	82 [21.66]	128 [33.81]	125 [33]	201 [53.06]	257 [67.89]	282 [74.45]	316 [83.42]	350 [92.4]	388 [102.5]	433 [114.31]	500 [132]	590 [155.76]	641 [169.22]
Potenza max. a p <sub>nom</sub> Max. power at p <sub>nom</sub>		P <sub>max</sub>	kW [hp]	59 [79.1]	92 [123.4]	90 [120.6]	144 [192.96]	184 [246.7]	202 [270.68]	226 [302.84]	251 [336.34]	278 [372]	310 [415.4]	358 [479.72]	423 [566.82]	459 [615.06]
Costante di coppia Torque constant		T <sub>k</sub>	Nm/bar [lbf-ft/psi]	0.16 [0.008]	0.25 [0.013]	0.3 [0.015]	0.5 [0.025]	0.73 [0.037]	0.9 [0.045]	1 [0.05]	1.2 [0.06]	1.4 [0.07]	1.7 [0.085]	2 [0.1]	2.6 [0.13]	2.8 [0.14]
Coppia max. Max. torque	cont. (p <sub>nom</sub> )	T <sub>nom</sub>	Nm [lbf-ft]	71 [52.36]	110 [81.13]	136 [100.23]	218 [160.66]	315 [232.33]	386 [284.48]	433 [319.12]	533 [392.82]	590 [435.13]	742 [546.85]	855 [630.13]	1122 [826.91]	1219 [898.40]
	picco peak (p <sub>max</sub> )	T <sub>max</sub>	Nm [lbf-ft]	79 [58.27]	122 [89.98]	152 [112.02]	244 [179.82]	352 [260.36]	431 [317.65]	484 [356.71]	595 [438.51]	659 [486.05]	829 [610.97]	954 [703.10]	1253 [923.46]	1361 [1003.06]
Momento di inerzia <sup>(3)</sup> Moment of inertia <sup>(3)</sup>		J	kg·m <sup>2</sup> [lbf-ft <sup>2</sup> ]	0.0005 [0.0118]	0.0005 [0.0118]	0.001 [0.0235]	0.001 [0.0235]	0.004 [0.094]	0.004 [0.094]	0.004 [0.094]	0.007 [0.1645]	0.007 [0.1645]	0.012 [0.2820]	0.012 [0.2820]	0.022 [0.5170]	0.022 [0.5170]
Peso <sup>(3)</sup> Weight <sup>(3)</sup>		m	kg [lbs]	6 [13.22]	6 [13.22]	10 [22.04]	10 [22.04]	18 [39.68]	19 [41.876]	19 [41.876]	23.7 [52.23]	23.7 [52.23]	35 [77.14]	35 [77.14]	48 [105.79]	48 [105.79]
Portata di drenaggio <sup>(4)</sup> External drain flow <sup>(4)</sup>		q <sub>d</sub>	l/min [U.S. gpm]	0.8 [0.2113]	0.8 [0.2113]	1 [0.264]	1 [0.264]	1.2 [0.317]	1.2 [0.317]	1.2 [0.317]	2.5 [0.66]	2.5 [0.66]	3 [0.79]	3 [0.79]	3 [0.79]	3 [0.79]

\* In fase di completamento - Work in progress

(Valori teorici, senza considerare  $\eta_{hm}$  e  $\eta_v$ ; valori arrotondati). Le condizioni di picco non devono durare più dell'1% di ogni minuto. Evitare il funzionamento contemporaneo alla massima velocità e alla massima pressione.

(Theoretical values, without considering  $\eta_{hm}$  e  $\eta_v$  approximate values). Peak operations must not exceed 1% of every minute. A simultaneous maximum pressure and maximum speed not recommended.

### Note: Determinazione della velocità ammissibile

<sup>(3)</sup> Valori indicativi. <sup>(4)</sup> Valori medi a 250 bar con olio minerale a 45°C e viscosità 35 cSt.

### Notes: Calculation of permissible speed

<sup>(3)</sup> Approximate values. <sup>(4)</sup> Average values at 250 bar [3600 psi] with mineral oil at 45°C [113°F] and 35 cSt of viscosity.

### Determinazione della velocità limite / Speed limits calculation

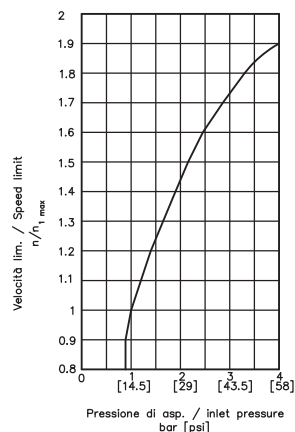

# CODICE DI ORDINAZIONE ORDERING CODE

Le seguenti lettere o numeri del codice, sono state sviluppate per identificare tutte le configurazioni possibili dei motori SH11C. Usare il seguente modulo per identificare le caratteristiche desiderate. **Tutte le lettere o numeri del codice devono comparire in fase d'ordine.** Si consiglia di leggere attentamente il catalogo prima di iniziare la compilazione del codice di ordinazione.

The following alphanumeric codes system has been developed to identify all of the configuration options for the SH11C motors. Use the model code below to specify the desired features. **All alphanumeric digits system of the code must be present when ordering.** We advise to carefully read the catalogue before filling the ordering code.

## CODICE PRODOTTO / MODEL CODE

1	2	3	4	5	6	7	8	9	10	11	12	13	14

### 1 - SERIE / SERIES

SH11C	Unità a pistoni assiali, con corpo inclinato a cilindrata fissa Fixed displacement, bent axis, axial piston unit
-------	---

### 2 - MOTORE / MOTOR

M	Motore Motor
---	-----------------

### 3 - CILINDRATA / DISPLACEMENT

010*	10.3 cm <sup>3</sup> /giro	0.626 in <sup>3</sup> /rev
016*	16 cm <sup>3</sup> /giro	0.976 in <sup>3</sup> /rev
020	20 cm <sup>3</sup> /giro	1.22 in <sup>3</sup> /rev
030	30 cm <sup>3</sup> /giro	1.83 in <sup>3</sup> /rev
045*	46 cm <sup>3</sup> /giro	2.807 in <sup>3</sup> /rev
055	55 cm <sup>3</sup> /giro	3.355 in <sup>3</sup> /rev
063	63 cm <sup>3</sup> /giro	3.843 in <sup>3</sup> /rev
075	75 cm <sup>3</sup> /giro	4.575 in <sup>3</sup> /rev
090	90 cm <sup>3</sup> /giro	5.49 in <sup>3</sup> /rev
108	108 cm <sup>3</sup> /giro	6.588 in <sup>3</sup> /rev
125	125 cm <sup>3</sup> /giro	7.625 in <sup>3</sup> /rev
160	160 cm <sup>3</sup> /giro	9.76 in <sup>3</sup> /rev
180	180 cm <sup>3</sup> /giro	10.98 in <sup>3</sup> /rev

### 4 - VERSIONE / VERSION

ME	ISO
SE	SAE

### CILINDRATA / DISPLACEMENT

010*-016*	020-030	045*-055-063	075-090	108-125	160-180
-----------	---------	--------------	---------	---------	---------

### 5 - FLANGIA / MOUNT FLANGE

OA	OB	OC	OD	OE	OF	02	05	08
ISO 4 fori Ø 80 mm ISO 4 Bolts Ø 80 mm [Ø 3.15 in]	ISO 4 fori Ø 100 mm ISO 4 Bolts Ø 100 mm [Ø 3.937 in]	ISO 4 fori Ø 125 mm ISO 4 Bolts Ø 125 mm [Ø 4.921 in]	ISO 4 fori Ø 140 mm ISO 4 Bolts Ø 140 mm [Ø 5.511 in]	ISO 4 fori Ø 160 mm ISO 4 Bolts Ø 160 mm [Ø 6.299 in]	ISO 4 fori Ø 180 mm ISO 4 Bolts Ø 180 mm [Ø 7.086 in]	SAE-C 4 Fori SAE-C 4 Bolts	SAE-C 4 Fori SAE-C 4 Bolts	SAE-D 4 Fori SAE-D 4 Bolts
ME	/	/	/	/	/	SE	/	/
/	ME	/	/	/	/	/	SE	/
/	/	ME	/	/	/	/	SE	/
/	/	/	ME	/	/	/	SE	/
/	/	/	/	ME	/	/	/	/
/	/	/	/	/	/	/	SE	ME
/	/	/	/	/	/	/	/	SE

\* In fase di completamento - Work in progress

1) Il valore ME indica che la flangia è disponibile solo per la versione ISO  
The ME digit means that the flange is only available for the ISO version

2) Il valore SE indica che la flangia è disponibile solo per la versione SAE  
The SE digit means that the flange is only available for the SAE version



1	2	3	4	5	6	7	8	9	10	11	12	13	14

		CILINDRATA / DISPLACEMENT					
		010*-016*	020-030	045*-055-063	075-090	108-125	160-180
<b>6 - ESTREMITÀ ALBERO / SHAFT END</b>							
CAV	Cilindrico Ø20 mm k6 - Linguetta 8x6x30 Parallel keyed Ø20 mm k6 [0.984 in k6] - key 0.23x0.23x1.18	ME	/	/	/	/	/
CMB	Cilindrico Ø25 mm k6 - Linguetta 8x7x32 Parallel keyed Ø 25 mm k6 [0.984 in k6] - key 0.31x0.27x1.57	ME	/	/	/	/	/
CBM	Cilindrico Ø25 mm k6 - Linguetta 8x7x40 Parallel keyed Ø 25 mm k6 [0.984 in k6] - key 0.31x0.27x1.57	/	ME	/	/	/	/
CBN	Cilindrico Ø 30 mm k6 - Linguetta 8x7x40 Parallel keyed Ø 30 mm k6 [1.181 in k6] - key 0.31x0.27x1.57	/	ME	/	/	/	/
CAW	Cilindrico Ø 30 mm k6 - Linguetta 8x7x50 Parallel keyed Ø 30 mm k6 [1.181 in k6] - key 0.31x0.27x1.97	/	/	ME	/	/	/
CBP	Cilindrico Ø 40 mm k6 - Linguetta 12x8x56 Parallel keyed Ø 40 mm k6 [1.574 in k6] - Key 0.47x0.31x2.204	/	/	/	ME	/	/
CAK	Cilindrico Ø 40 mm k6 - Linguetta 12x8x63 Parallel keyed Ø 40 mm k6 [1.574 in k6] - Key 0.47x0.31x2.48	/	/	/	/	ME	/
CAJ	Cilindrico Ø 45 mm k6 - Linguetta 14x9x63 Parallel keyed Ø 45 mm k6 [1.772 in k6] - Key 0.55x0.35x2.48	/	/	/	/	ME-SE	/
CBQ	Cilindrico Ø 45 mm k6 - Linguetta 14x9x70 Parallel keyed Ø 45 mm k6 [1.772 in k6] - Key 0.55x0.35x2.75	/	/	/	/	/	ME
CAX	Cilindrico Ø 50 mm k6 - Linguetta 14x9x70 Parallel keyed Ø 50 mm k6 [1.968 in k6] - Key 0.55x0.35x2.75	/	/	/	/	/	ME-SE
CAY	Cilindrico Ø 35 mm k6 - Linguetta 10x8x56 Parallel keyed Ø 35 mm k6 [1.377 in k6] - Key 0.39x0.31x2.204	/	/	/	ME	/	/
SAF	Scanalato W20x1.25x30x14x9g DIN 5480 Splined W20x1.25x30x14x9g DIN 5480	ME	/	/	/	/	/
SAG	Scanalato W25x1.25x18x9g DIN 5480 Splined W25x1.25x18x9g DIN 5480	ME	ME	/	/	/	/
SAI	Scanalato W30x2x14x9g DIN 5480 Splined W30x2x14x9g DIN 5480	/	ME	ME	/	/	/
SAM	Scanalato W35x2x16x9g DIN 5480 Splined W35x2x16x9g DIN 5480	/	/	ME	ME	/	/
SAO	Scanalato W40x2x18x9g DIN 5480 Splined W40x2x18x9g DIN 5480	/	/	/	ME	ME	/
SAP	Scanalato W45x2x21x9g DIN 5480 Splined W45x2x21x9g DIN 5480	/	/	/	/	ME	ME
SAR	Scanalato W50x2x24x9g DIN 5480 Splined W50x2x24x9g DIN 5480	/	/	/	/	/	ME
C16	Cilindrico Ø 22.22 mm - Linguetta 6.35x6.25x25.4 Parallel keyed Ø 22.22 mm [0.874 in] - Key 0.25x0.246x1	/	SE	/	/	/	/
C17	Cilindrico Ø 31.75 mm - Linguetta 7.93x7.3x40 Parallel keyed Ø 31.75 mm [1.25 in] - Key 0.31x0.287x1.57	/	/	SE	/	/	/
C18	Cilindrico Ø 44.45 mm - Linguetta 11.11x9.2x60 Parallel keyed Ø 44.45 mm [1.75 in] - Key 0.43x0.36x2.36	/	/	/	/	SE	SE
S05	Scanalato Z13 16/32 DP Splined 13T 16/32 DP	SE	SE	/	/	/	/
S12	Scanalato Z14 12/24 DP Splined 14T 12/24 DP	/	SE	SE	SE	/	/
S15	Scanalato Z13 8/16 DP Splined 13T 8/16 DP	/	/	/	/	SE	SE
S16	Scanalato Z23 16/32 DP Splined 23T 16/32 DP	/	/	/	/	SE	/

\* In fase di completamento - Work in progress

- 1) Il valore ME indica che l'albero è disponibile solo per la versione ISO  
The ME digit means that the shaft is only available for the ISO version  
2) Il valore SE indica che l'albero è disponibile solo per la versione SAE  
The SE digit means that the shaft is only available for the SAE version

1	2	3	4	5	6	7	8	9	10	11	12	13	14
---	---	---	---	---	---	---	---	---	----	----	----	----	----

		CILINDRATA / DISPLACEMENT					
		010*-016*	020-030	045*-055-063	075-090	108-125	160-180
<b>7 - COPERCHIO DISTRIBUTORE / PORT COVER</b>							
LM1	Bocche Laterali Lateral ports	SE	/	/	/	/	/
LM2	Bocche Laterali Lateral ports	Pag.25	/	ME-SE	ME-SE	ME-SE	ME-SE
LM3	Bocche Laterali Lateral ports		/	ME	ME	/	/
FM2	Bocche Frontali Frontal ports		ME	ME-SE	ME-SE	ME-SE	ME-SE
FM3	Bocche Frontali Frontal ports		ME	ME	ME	/	/
VM2	Bocche Laterali affiancate Lateral ports same side	Pag.26	/	ME-SE	ME-SE	ME-SE	ME-SE
VMD	Bocche Laterali affiancate con valvola DX Lateral ports same side with valve CW	Pag.26	ME	/	/	/	/
VMS	Bocche Laterali affiancate con valvola SX Lateral ports same side with valve CCW	Pag.26	ME	/	/	/	/

\* In fase di completamento - Work in progress

- 1) Il valore ME indica che il coperchio è disponibile solo per la versione ISO  
The ME digit means that the port cover is only available for the ISO version
- 2) Il valore SE indica che il coperchio è disponibile solo per la versione SAE  
The SE digit means that the port cover is only available for the SAE version

<b>8 - SENSO DI ROTAZIONE (VISTA LATO ALBERO) / DIRECTION OF ROTATION (VIEWED FROM SHAFT SIDE)</b>	
RV	Reversibile Reversible

<b>9 - TENUTA / SEAL</b>	
V	FKM

		CILINDRATA / DISPLACEMENT					
		010*-016*	020-030	045*-055-063	075-090	108-125	160-180
<b>10 - VALVOLA / VALVE</b>							
XXXX	Non Richieste NONE	•	•	•	•	•	•
VCDM	Valvola controllo discesa VCD/M VCD/M Pilot assisted overcentre valve	/	VM2-FM2	VM2-FM2	VM2-FM2	VM2-FM2	VM2-FM2
VCD1	Valvola controllo discesa VCD/1 VCD/1 Pilot assisted overcentre valve	/	/	LM2	LM2	LM2	LM2
VCD2	Valvola controllo discesa VCD/2 VCD/2 Pilot assisted overcentre valve	/	/	/	LM2	LM2	LM2
VCR1	Valvola controllo rotazione VCR1 D/AF VCR1 D/AF Double acting overcentre valve	/	VM2-FM2	/	/	/	/
VCR3	Valvola controllo rotazione VCR3 VCR3 Double acting overcentre valve	/	/	VM2-FM2	VM2-FM2	VM2-FM2	VM2-FM2
VU16	Valvola unidirezionale VU165 VU165 Check valve	/	/	/	LM2	/	/

• Disponibile - Available / Non Disponibile - Not Available

\* In fase di completamento - Work in progress

Le valvole sono disponibili solo con coperchi distributori ISO, per versione SAE contattare Uff.Tecnico.  
The valves are available with ISO port cover only, please contact Technical department for SAE version

1) I valori VM2-FM2-LM2 indicano che le valvole sono disponibili solo con coperchi VM2-FM2-LM2  
The VM2-FM2-LM2 digits means that the valves are only available with VM2-FM2-LM2 port covers

1	2	3	4	5	6	7	8	9	10	11	12	13	14

VALVOLA / VALVE						
XXXX	VCDM	VCD1	VCD2	VCR1	VCR3	VU16

### 11 - CARATTERISTICA VALVOLA / VALVE FEATURE

000	Caratteristica non necessaria Feature not necessary	•	/	/	/	/	•	/
001	Non Tarata (Campo Taratura 30+350 bar) (Rapporto di pilotaggio 6.2:1) Not Set 30+350 bar [435 to 5075 psi] [Piloting ratio 6.2:1]	/	/	/	/	•	/	/
002	Non Tarata (Campo Taratura 0+350 bar) (Rapporto di pilotaggio 2.9:1) - Controllo in rotazione DX Not Set 0+350 bar [0 to 5075 psi] [Piloting ratio 2.9:1] - Control of rotation CW	/	/	•	/	/	/	/
006	Non Tarata (Campo Taratura 0+350 bar) (Rapporto di pilotaggio 2.9:1) - Controllo in rotazione SX Not Set 0+350 bar [0 to 5075 psi] [Piloting ratio 2.9:1] - Control of rotation CCW	/	/	•	/	/	/	/
004	Non Tarata (Campo Taratura 30+350 bar) (Rapporto di pilotaggio 6.2:1) - Controllo in rotazione DX Not Set 30+350 bar [435 to 5075 psi] [Piloting ratio 6.2:1] - Control of rotation CW	/	•	/	/	/	/	/
005	Non Tarata (Campo Taratura 30+350 bar) (Rapporto di pilotaggio 6.2:1) - Controllo in rotazione SX Not Set 30+350 bar [435 to 5075 psi] [Piloting ratio 6.2:1] - Control of rotation CCW	/	• <sup>(1)</sup>	/	/	/	/	/
003	Non Tarata (Campo Taratura 250+500 bar) (Rapporto di pilotaggio 13:1) - Controllo in rotazione DX Not Set 250+500 bar [3625 to 7250 psi] [Piloting ratio 13:1] - Control of rotation CW	/	/	/	•	/	/	/
007	Non Tarata (Campo Taratura 250+500 bar) (Rapporto di pilotaggio 13:1) - Controllo in rotazione SX Not Set 250+500 bar [3625 to 7250 psi] [Piloting ratio 13:1] - Control of rotation CCW	/	/	/	•	/	/	/
008	Non Tarata (Taratura Massima 350 bar, Portata Massima 65 l/min) - Controllo in rotazione DX Not Set (Max setting 350 bar[5075 psi], Max Flow 65 l/min [17.2 U.S. gpm]) - Control of rotation CW	/	/	/	/	/	/	•
009	Non Tarata (Taratura Massima 350 bar, Portata Massima 65 l/min) - Controllo in rotazione SX Not Set (Max setting 350bar[5075 psi], Max Flow 65l/min[17.2 U.S. gpm]) - Control of rotation CCW	/	/	/	/	/	/	•

• Disponibile - Available / Non Disponibile - Not Available

Per la fornitura di valvole tarate contattare Uff. Tecnico.  
Please contact Technical department for valve which require specific setting

Per le caratteristiche vedere il catalogo valvole  
For the technical specifications see catalogue valves

(1) Non disponibile con coperchio distributore VM2.  
(1) Not available with VM2 port cover.

CILINDRATA / DISPLACEMENT					
010*-016*	020-030	045*-055-063	075-090	108-125	160-180

### 12 - VALVOLA DI LAVAGGIO / FLUSHING VALVE

XX	Non Richieste NONE	•	•	•	•	•	•
PR	Predisposto per valvola di lavaggio Arranged for Flushing Valve	/	LM2	LM2	LM2	LM2	LM2
06	Valvola di lavaggio VSC/F - 6 l/min VSC/F Flushing valve - 6 l/min [1.58 U.S. gpm]	/	LM2-VM2	LM2-VM2	LM2-VM2	LM2-VM2	LM2-VM2
09	Valvola di lavaggio VSC/F - 10.5 l/min VSC/F Flushing valve - 10.5 l/min [2.77 U.S. gpm]	/	LM2-VM2	LM2-VM2	LM2-VM2	LM2-VM2	LM2-VM2
15	Valvola di lavaggio VSC/F - 15 l/min VSC/F Flushing valve - 15 l/min [3.96 U.S. gpm]	/	LM2-VM2	LM2-VM2	LM2-VM2	LM2-VM2	LM2-VM2
21	Valvola di lavaggio VSC/F - 20 l/min VSC/F Flushing valve - 20 l/min [5.28 U.S. gpm]	/	LM2-VM2	LM2-VM2	LM2-VM2	LM2-VM2	LM2-VM2

• Disponibile - Available / Non Disponibile - Not Available \* In fase di completamento - Work in progress

Non è possibile combinare le valvole di lavaggio con le valvole in pos. 10  
It is not possible to combine the flushing valves with valve in pos.10

Per le caratteristiche vedere il catalogo valvole  
For the technical specifications see catalogue valves

1) Il valore LM2-VM2 indica che la valvola è disponibile solo con coperchio LM2 e VM2  
The LM2-VM2 digit means that the valve is only available with LM2 and VM2 port cover

1	2	3	4	5	6	7	8	9	10	11	12	13	14

		CILINDRATA / DISPLACEMENT					
		010*-016*	020-030	045*-055-063	075-090	108-125	160-180
<b>13 - CARATTERISTICA SPECIALE / SPECIAL FEATURE</b>							
<b>XX</b>	Nessuna Caratteristica NONE	•	•	•	•	•	•
<b>03</b>	Versione SAE con coperchio distributore ISO SAE version with ISO port cover	/	/	• <sup>1)</sup>	• <sup>2)</sup>	/	/
<b>RD</b>	Tappi drenaggio invertiti Drain plugs reversed	Pag.27 /	•	•	•	•	•
<b>TC</b>	Versione con Tachimetro + Sensore Tachometer version + Sensor	Pag.25 /	•	•	•	•	•

• Disponibile - Available / Non Disponibile - Not Available

1) Disponibile con coperchio distributore VM2  
Available with VM2 port cover

\* In fase di completamento - Work in progress

2) Disponibile con coperchio distributore FM2

<b>14 - VERNICIATURA / PAINTING</b>	
<b>XX</b>	Non Richieste NONE
<b>01</b>	Verniciato RAL 9005 Painted RAL 9005
<b>02</b>	Verniciato RAL 5015 Painted RAL 5015

**S1, S2: Drenaggi (1 tappato) / Drain ports (1 plugged) - 3/8 G (BSPP)**  
**A, B: UtENZE / Service line ports**  
**R: Spurgo (tappato) / Air bleed (plugged) - 1/8 G (BSPP)**

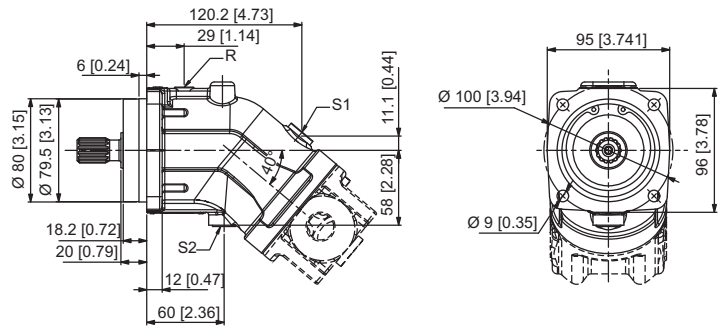

**FM3-LM3**

**VMD-VMS**

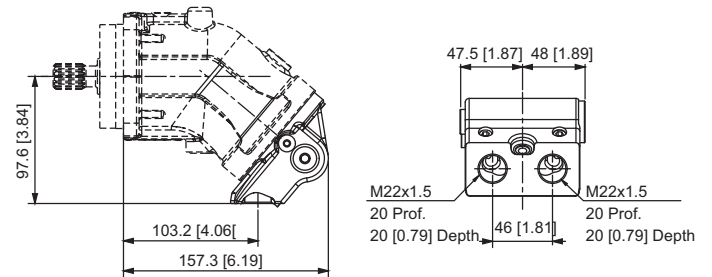
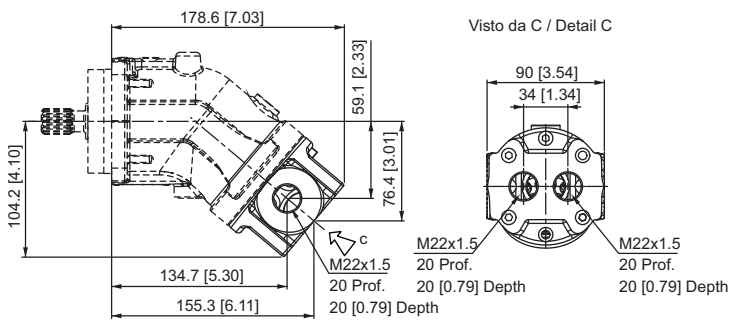

**CAV** *Albero cilindrico*  
Parallel keyed shaft

**CMB** *Albero cilindrico*  
Parallel keyed shaft

**SAG** *Albero scanalato*  
Splined shaft

**SAF** *Albero scanalato*  
Splined shaft

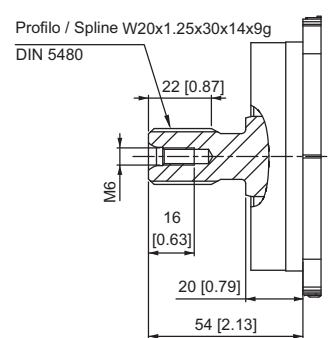
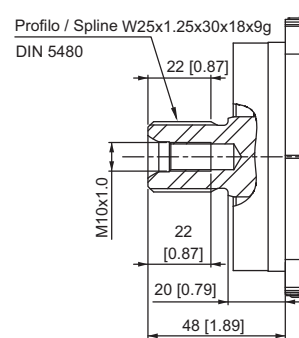
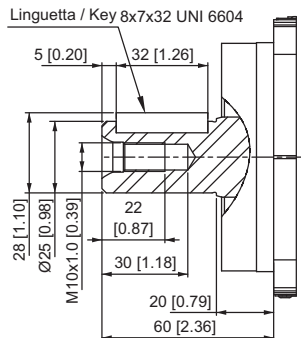
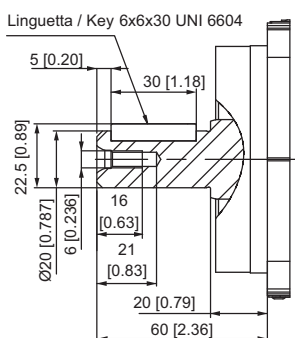

S1, S2: Drenaggi (1 tappato) / Drain ports (1 plugged) - 3/8 G (BSPP)  
 A, B: Utenze / Service line ports  
 R: Spurgo (tappato) / Air bleed (plugged) - 1/8 G (BSPP)

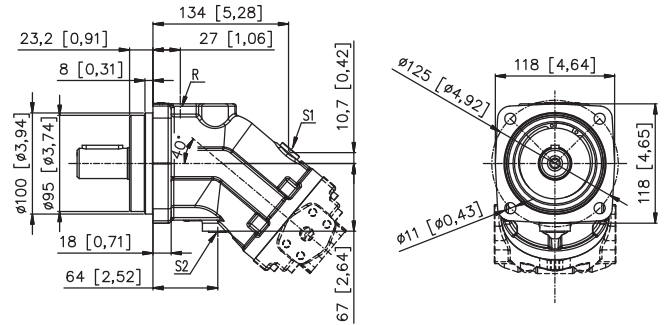

**FM3-LM3**

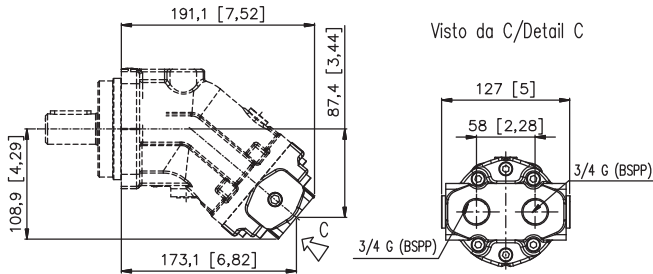

**FM2**

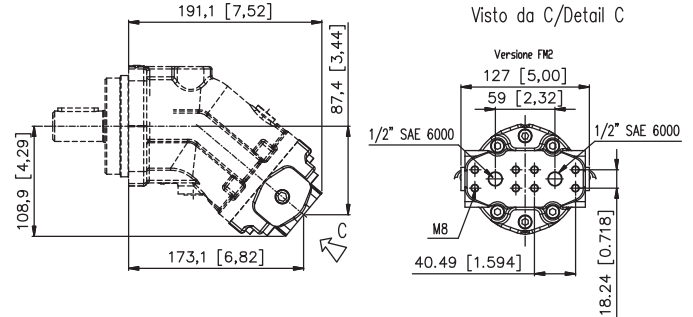

**VM2**

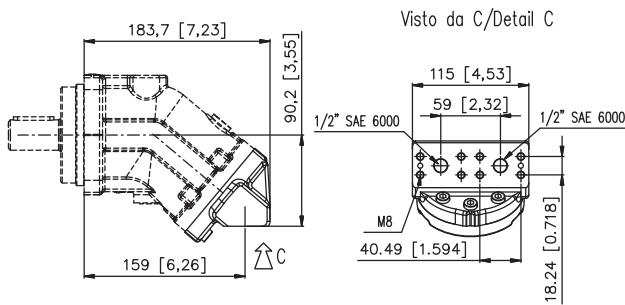

**LM2**

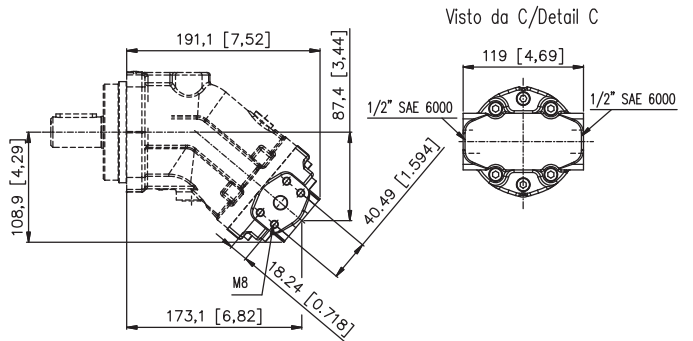

**CBM** *Albero cilindrico*  
Parallel keyed shaft

**CBN** *Albero cilindrico*  
Parallel keyed shaft

**SAG** *Albero scanalato*  
Splined shaft

**SAI** *Albero scanalato*  
Splined shaft

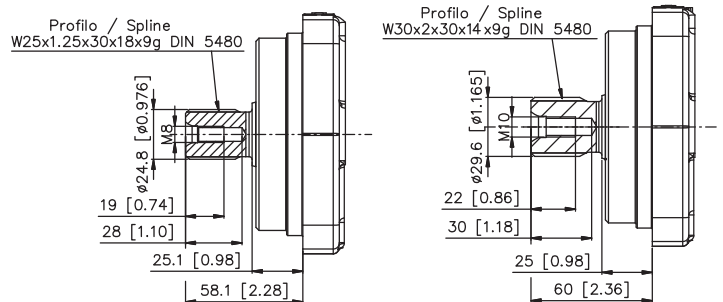
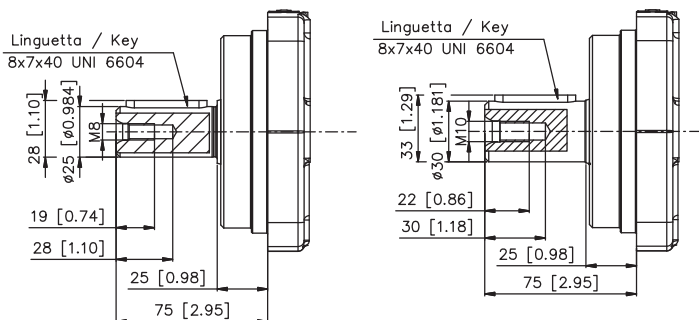

**S1, S2: Drenaggi (1 tappato) / Drain ports (1 plugged) - 1/2 G (BSPP)**  
**A, B: Utenze / Service line ports**  
**R: Spurgo (tappato) / Air bleed (plugged) - 1/8 G (BSPP)**

**LM2**

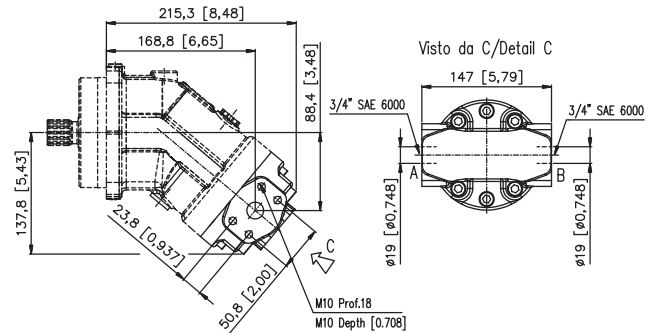
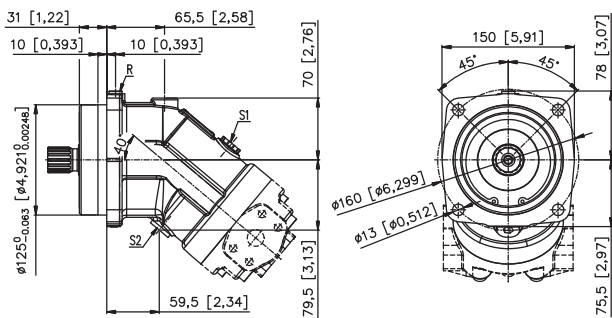

**FM3-LM3**

**FM2**

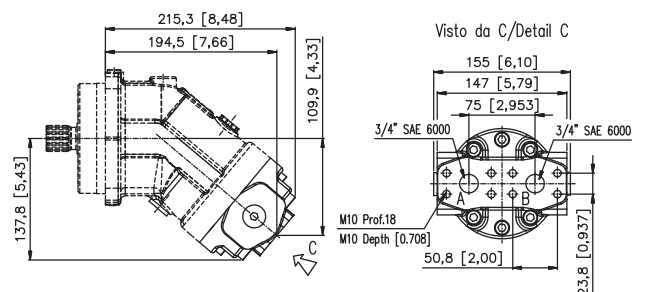
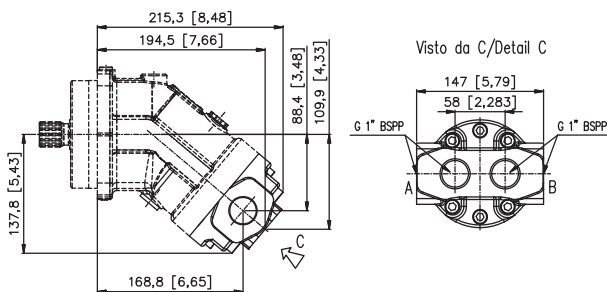

**VM2**

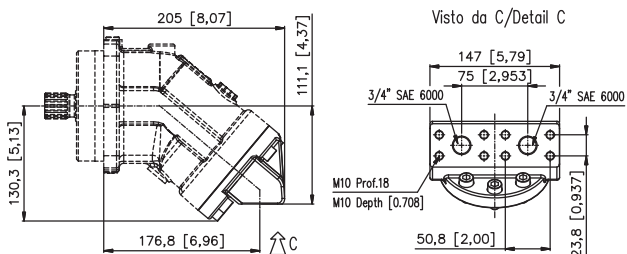

**CAW** *Albero cilindrico*  
Parallel keyed shaft

**SAM** *Albero scanalato*  
Splined shaft

**SAI** *Albero scanalato*  
Splined shaft

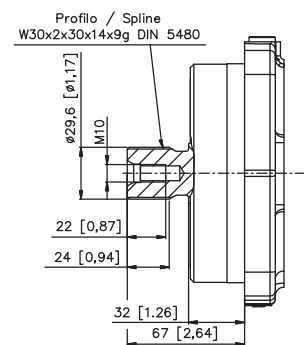
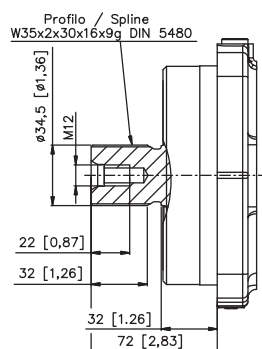
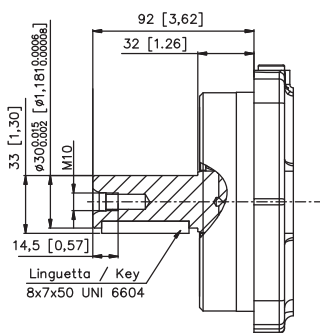

**S1, S2: Drenaggi (1 tappato) / Drain ports (1 plugged) - 1/2 G (BSPP)**  
**A, B: Utenze / Service line ports**  
**R: Spurgo (tappato) / Air bleed (plugged) - 1/8 G (BSPP)**

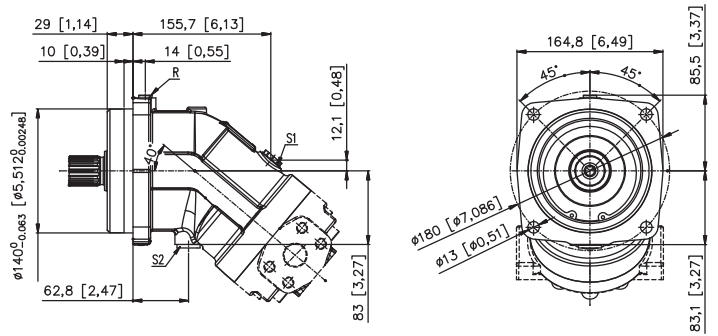

**LM2**

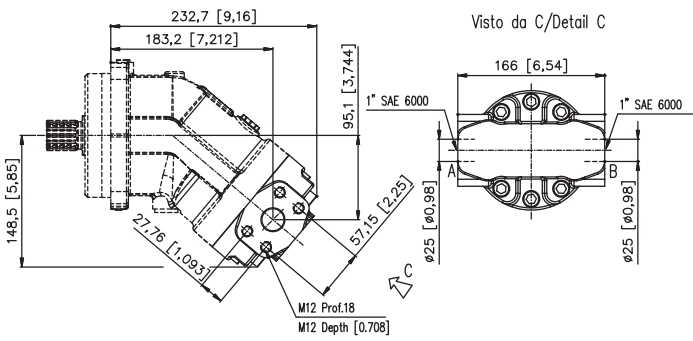

**FM2**

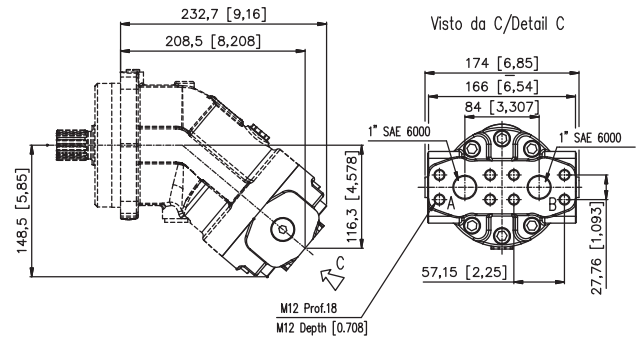

**VM2**

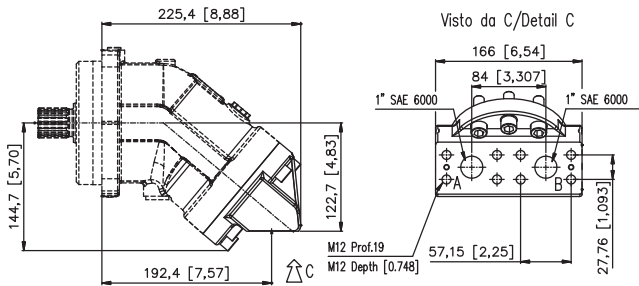

**CAY** *Albero cilindrico*  
Parallel keyed shaft

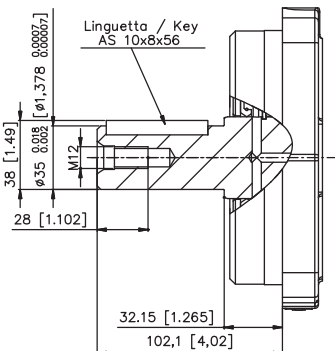

**CBP** *Albero cilindrico*  
Parallel keyed shaft

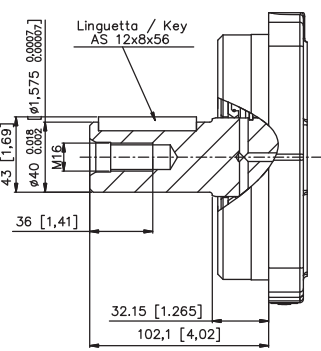

**SAM** *Albero scanalato*  
Splined shaft

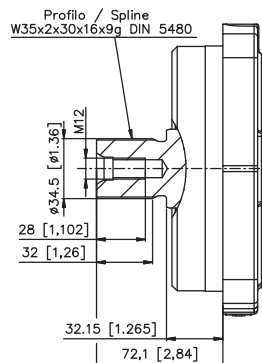

**SAO** *Albero scanalato*  
Splined shaft

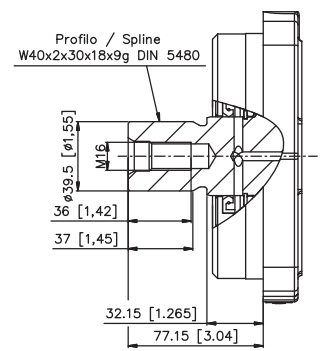



**S1, S2: Drenaggi (1 tappato) / Drain ports (1 plugged) - 1/2 G (BSPP)**  
**A, B: Utenze / Service line ports**  
**R: Spurgo (tappato) / Air bleed (plugged) - 1/8 G (BSPP)**

## LM2

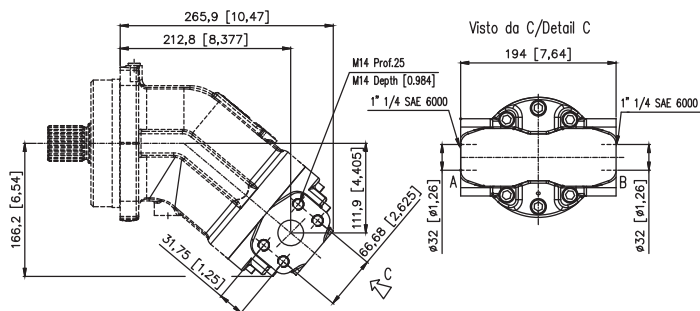
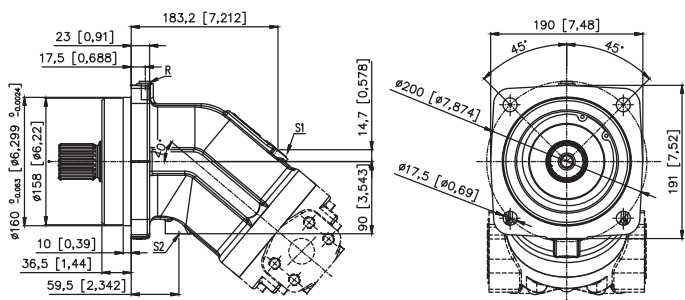

## FM1

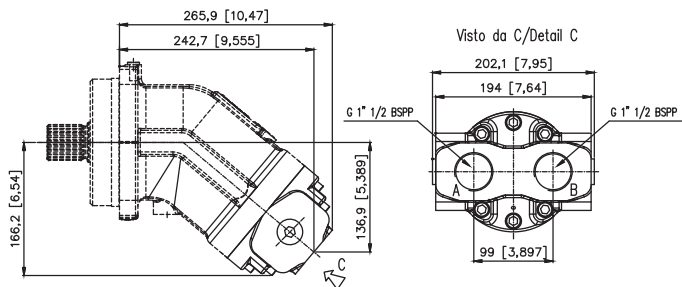

## FM2

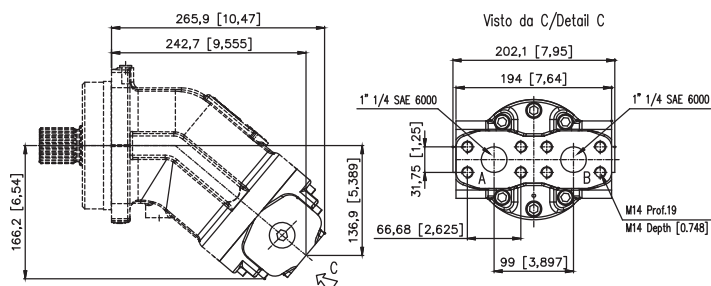

## VM2

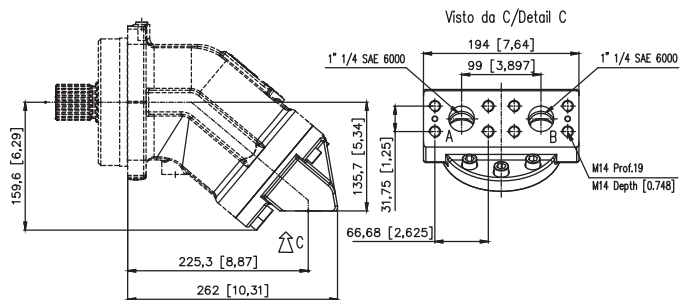

## CAK *Albero cilindrico* Parallel keyed shaft

## CAJ *Albero cilindrico* Parallel keyed shaft

## SAO *Albero scanalato* Splined shaft

## SAP *Albero scanalato* Splined shaft

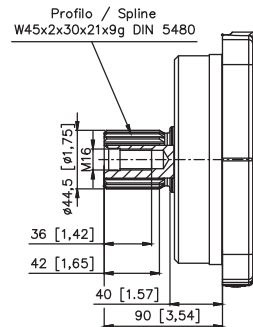
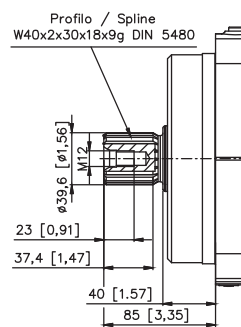
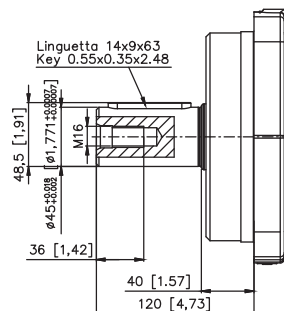
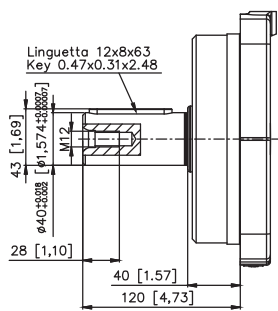

**S1, S2: Drenaggi (1 tappato) / Drain ports (1 plugged) - 3/4 G (BSPP)**  
**A, B: Utenze / Service line ports**  
**R: Spurgo (tappato) / Air bleed (plugged) - 1/8 G (BSPP)**

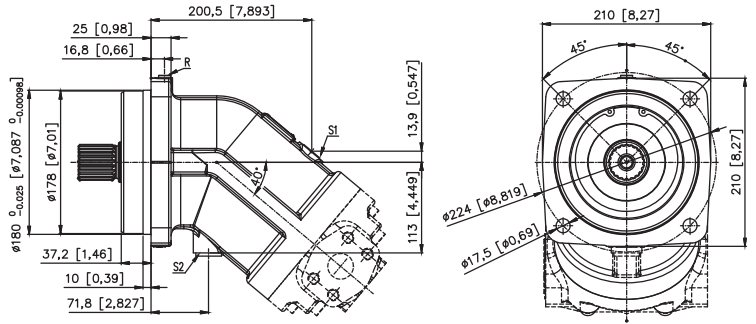

**LM2**

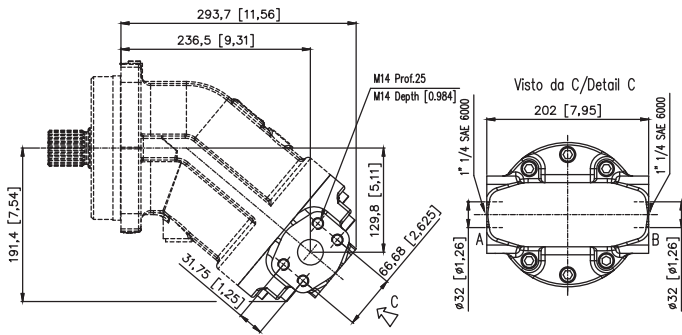

**FM2**

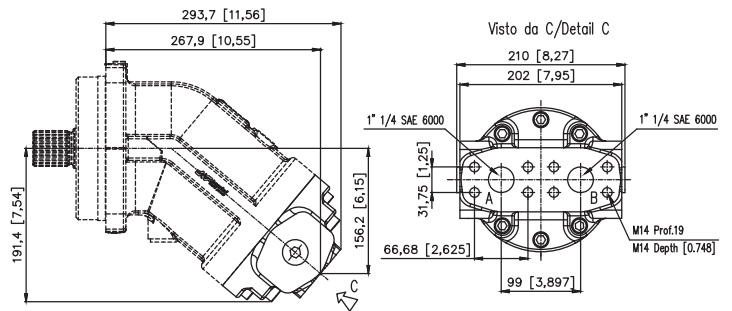

**VM2**

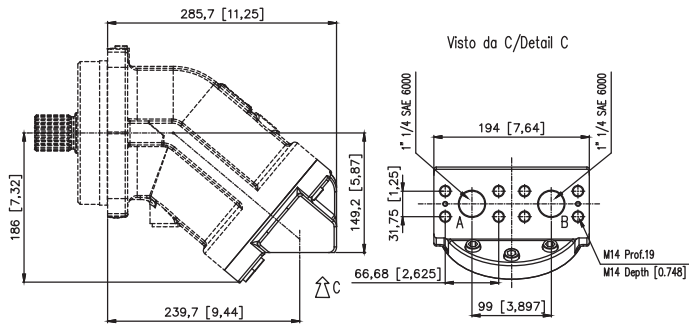

**CBQ** *Albero cilindrico*  
Parallel keyed shaft

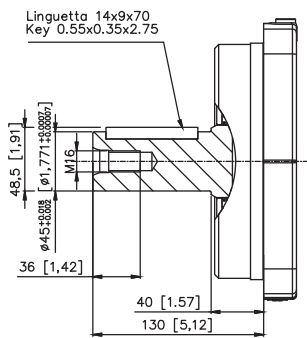

**CAX** *Albero cilindrico*  
Parallel keyed shaft

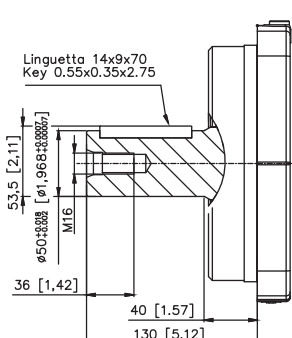

**SAP** *Albero scanalato*  
Splined shaft

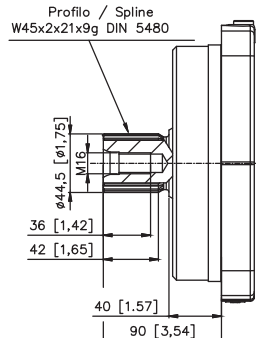

**SAR** *Albero scanalato*  
Splined shaft

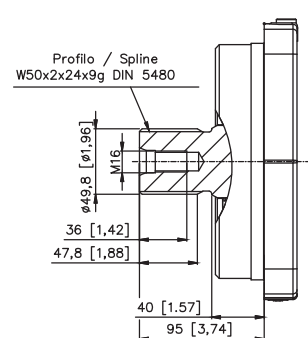

**S1, S2: Drenaggi (1 tappato) / Drain ports (1 plugged) - 3/4"-16 UNF 2B**  
**A, B: Utenze / Service line ports**  
**R: Spurgo (tappato) / Air bleed (plugged) - 7/16"-20 UNF 2B**

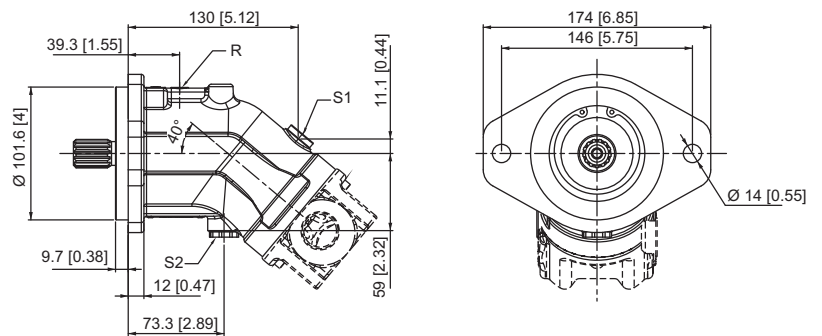

**LM1**

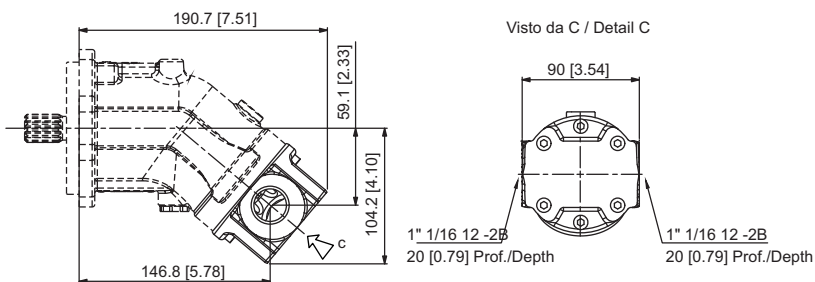

**S05** *Albero scanalato*  
**Splined shaft**

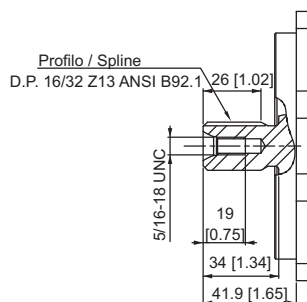

S1, S2: Drenaggi (1 tappato) / Drain ports (1 plugged) - 3/4"-16 UNF 2B  
 A, B: UtENZE / Service line ports  
 R: Spurgo (tappato) / Air bleed (plugged) - 7/16"-20 UNF 2B

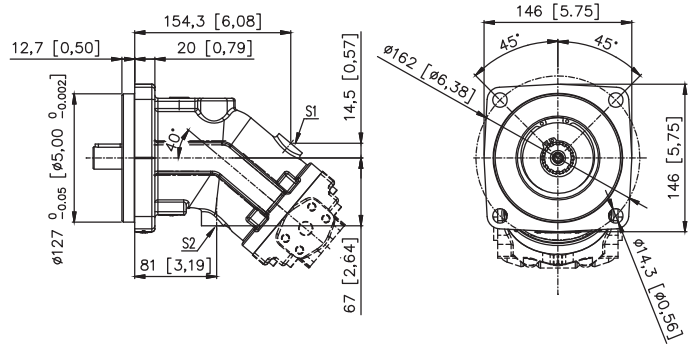

**LM2**

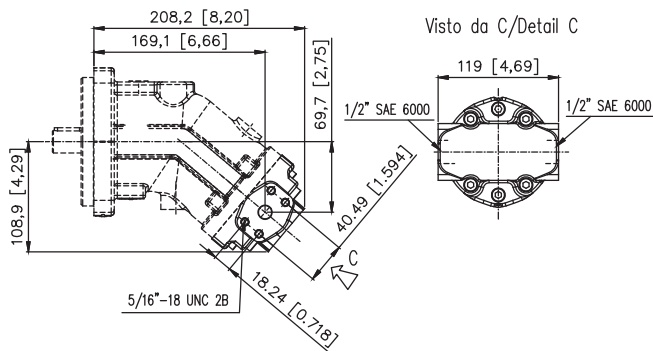

**FM2**

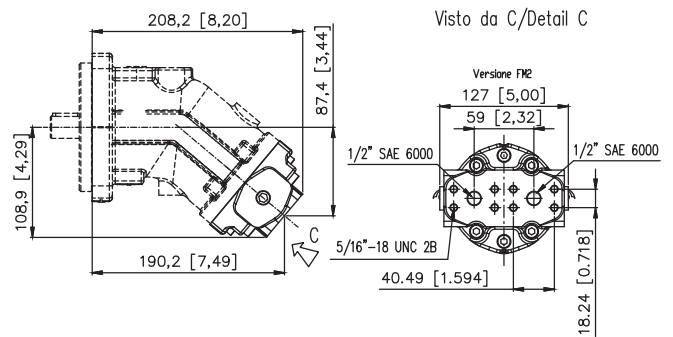

**VM2**

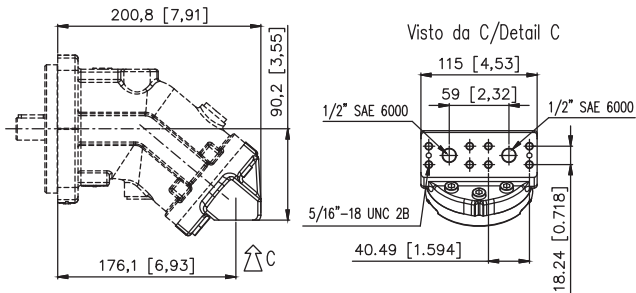

**C16** *Albero cilindrico*  
Parallel keyed shaft

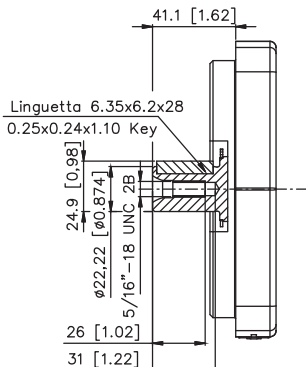

**S12** *Albero scanalato*  
Splined shaft

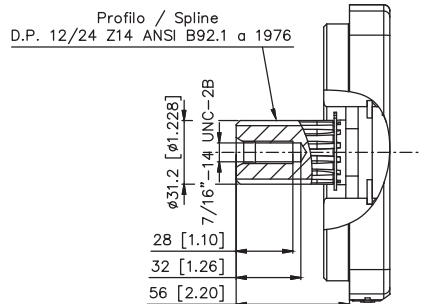

**S05** *Albero scanalato*  
Splined shaft

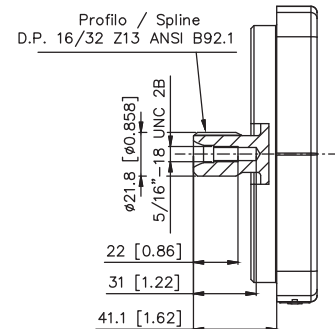

**S1, S2: Drenaggi (1 tappato) / Drain ports (1 plugged) - 1" 1/16-12 UN 2B**  
**A, B: Utenze / Service line ports**  
**R: Spurgo (tappato) / Air bleed (plugged) - 7/16"-20 UNF**

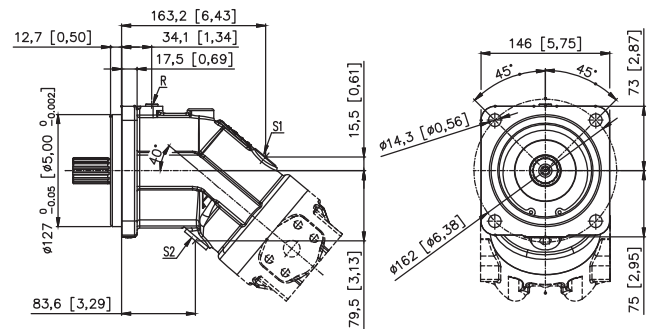

**LM2**

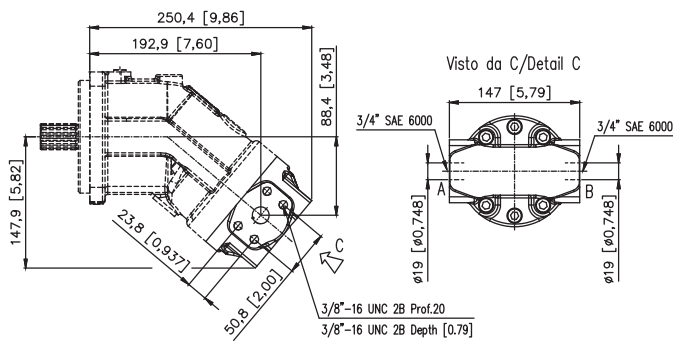

**FM2**

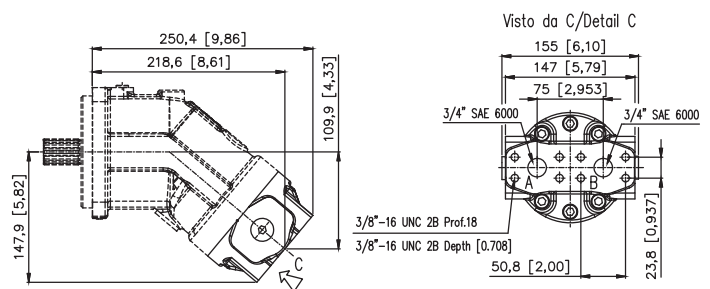

**VM2**

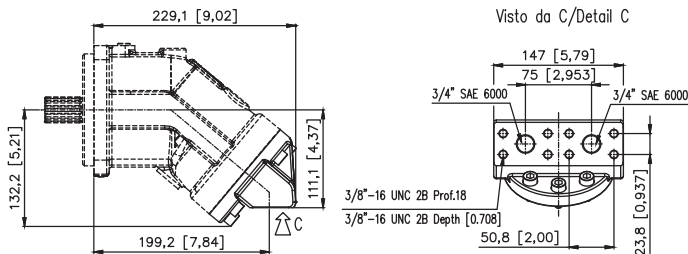

**C17** *Albero cilindrico*  
**Parallel keyed shaft**

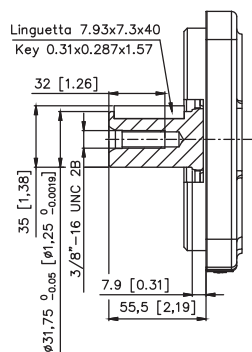

**S12** *Albero scanalato*  
**Splined shaft**

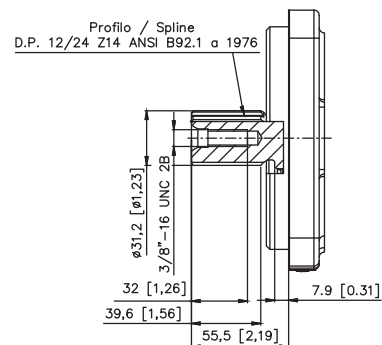

**S1, S2: Drenaggi (1 tappato) / Drain ports (1 plugged) - 1" 1/16-12 UN 2B**  
**A, B: Utenze / Service line ports**  
**R: Spurgo (tappato) / Air bleed (plugged) - 7/16"-20 UNF**

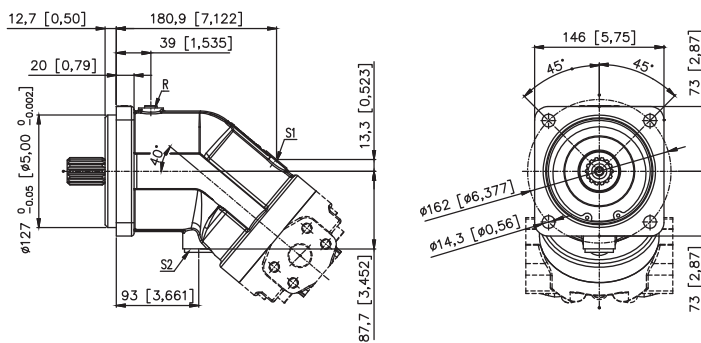

**LM2**

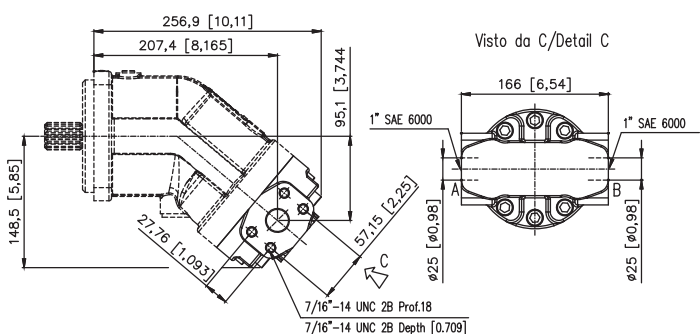

**FM2**

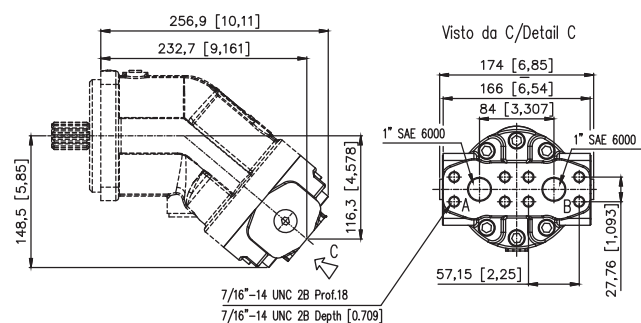

**VM2**

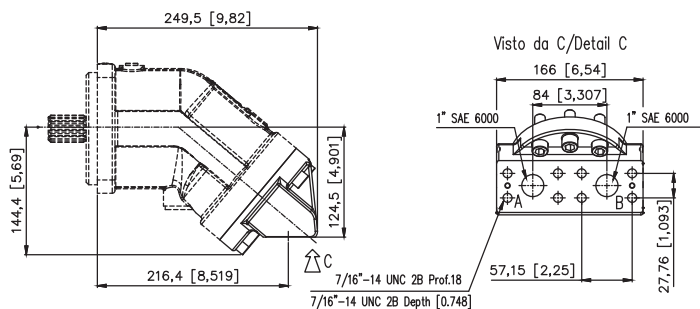

**S12** **Albero scanalato**  
**Splined shaft**

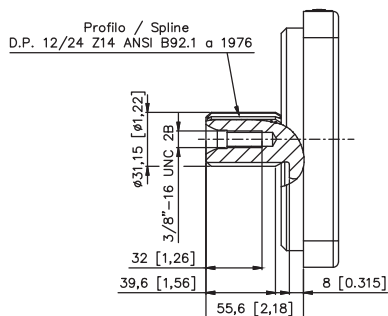

**S1, S2: Drenaggi (1 tappato) / Drain ports (1 plugged) - 1" 1/16-12 UN 2B**  
**A, B: Utenze / Service line ports**

**R: Spurgo (tappato) / Air bleed (plugged) - 7/16"-20 UNF**

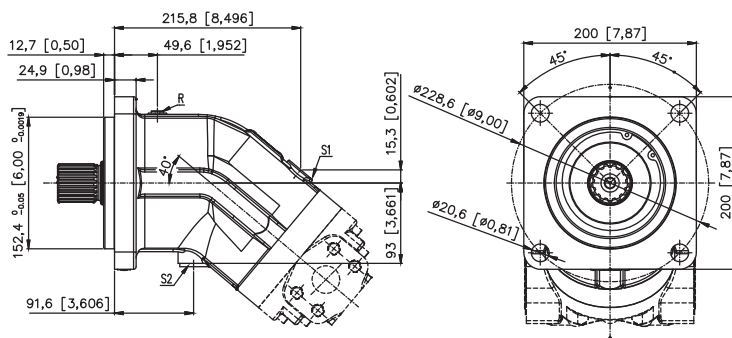

**LM2**

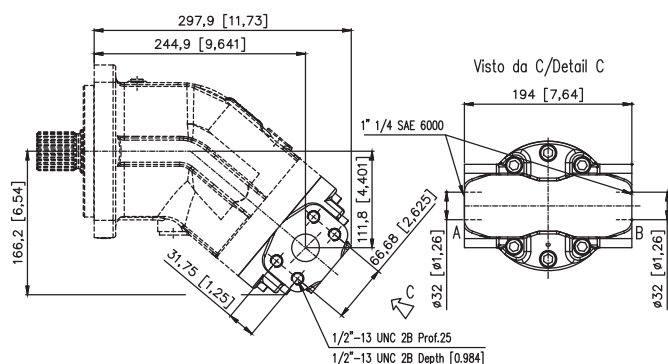

**FM2**

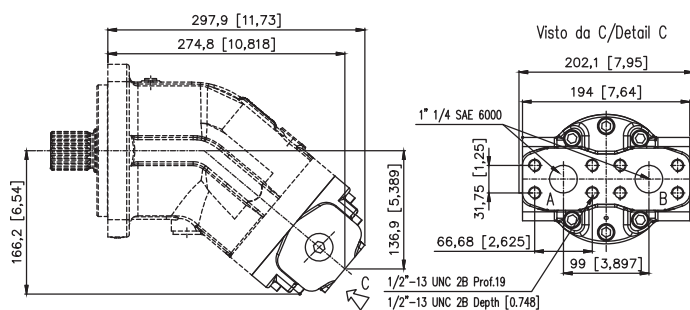

**VM2**

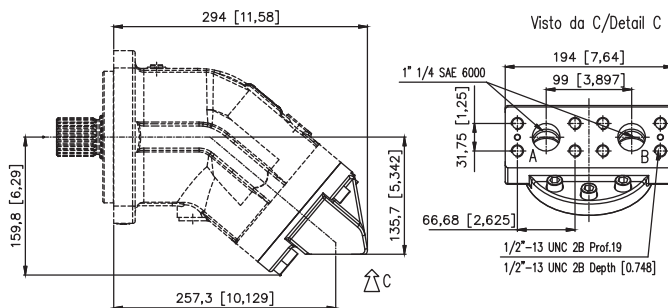

**C18**

**Albero cilindrico**  
**Parallel keyed shaft**

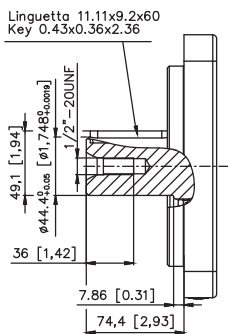

**S15**

**Albero scanalato**  
**Splined shaft**

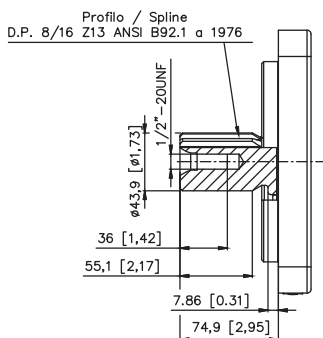

**S16**

**Albero scanalato**  
**Splined shaft**

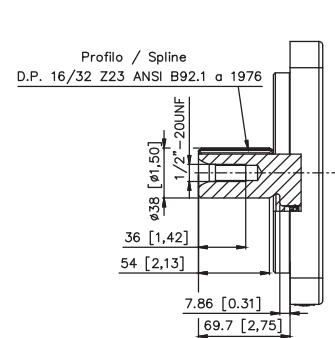

S1, S2: Drenaggi (1 tappato) / Drain ports (1 plugged) - 1" 1/16-12

UN 2B

A, B: Utenze / Service line ports

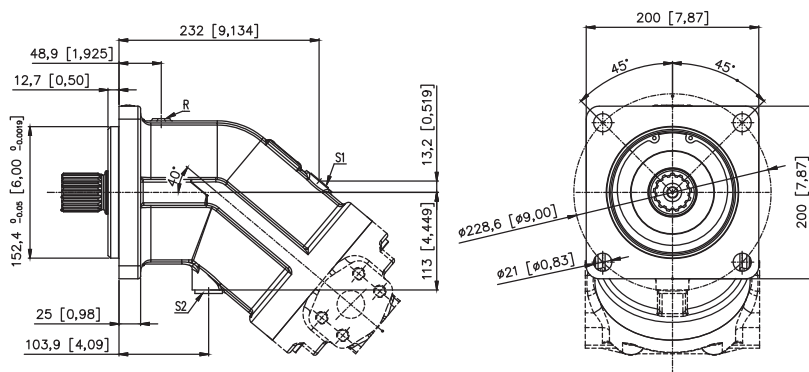

**LM2**

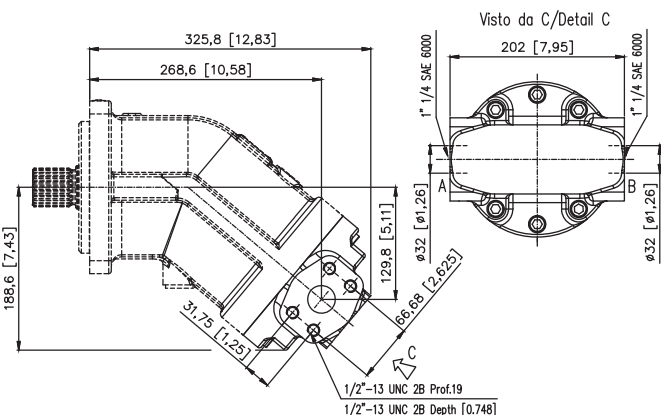

**FM2**

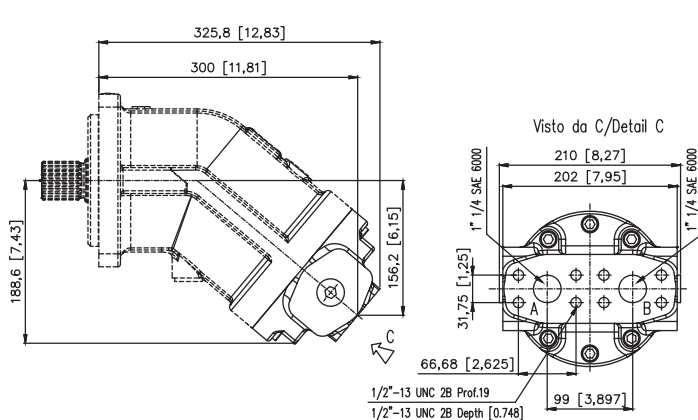

**VM2**

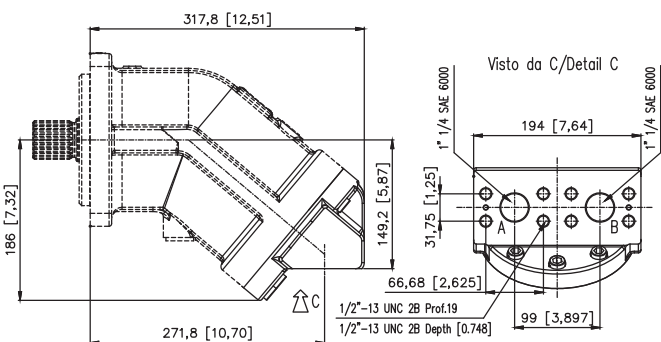

**C18**

Albero cilindrico  
Parallel keyed shaft

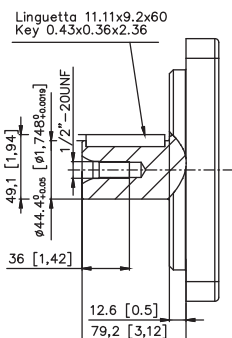

**S15**

Albero scanalato  
Splined shaft

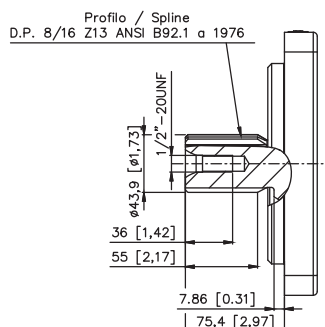



## VERSIONI SPECIALI SPECIAL VERSIONS

### VERSIONE CON TACHIMETRO TACHOMETER VERSION

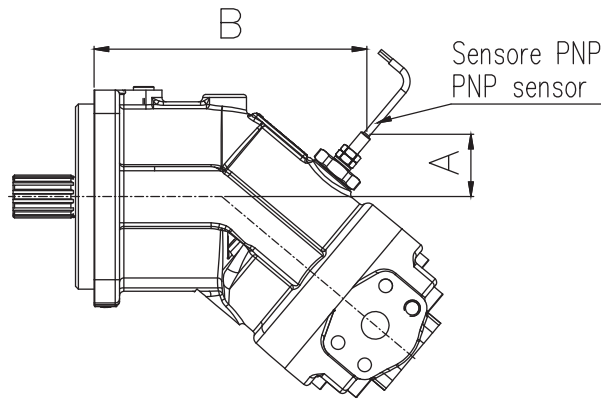

	010 ME 016 ME	020 ME 030 ME	045-055 ME 063 ME	075 ME 090 ME	108 ME 125 ME	160 ME 180 ME	010SE 016 SE	020 ME 030 SE	055 SE 063 SE	075 SE 090 SE	108 SE 125 SE	160 ME 180 SE
<b>A</b> mm [in]	/	38 [1.49]	41.7 [1.64]	37.5 [1.47]	41.9 [1.65]	42.5 [1.67]	/	43 [1.69]	41.7 [1.64]	37 [1.45]	42.9 [1.69]	42.5 [1.67]
<b>B</b> mm [in]	/	156 [6.14]	161.2 [6.35]	177 [6.99]	207.4 [8.16]	222.8 [8.77]	/	177 [6.96]	184.8 [7.27]	200.8 [7.87]	240.8 [9.48]	254.9 [10.03]

Segnale in uscita versione elettronica  
Output signal electronic tachometer

Numero d'impulsi per giro = 14  
Principio di funzionamento induttivo  
Funzione di uscita PNP  
Tensione nominale 10-30 V d.c.  
Caricabilità massima 200 mA  
Frequenza massima 1500 Hz  
Campo di temperatura -25°C +120°C  
Grado di protezione IP 67  
Versioni disponibili:

- Sensore con cavo a tre fili lunghezza 2 metri

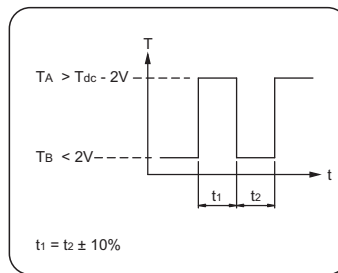

Number of pulses per revolution = 14  
Inductive principle  
Output current PNP  
Voltage 10-30 V d.c.  
Max load 200 mA  
Max frequency 1500 Hz  
Temperature range -25°C +120°C  
Enclosure IP 67  
Available versions:  
• Sensor with 2 metres three wires cable

Il sensore può essere montato solo sull'attacco drenaggio S1.

The sensor can be assembly only S1 drain port.

### VERSIONE CON VALVOLA DI LAVAGGIO FLUSHING VALVE VERSION

**LM2**

Coperchio distributore  
Port cover

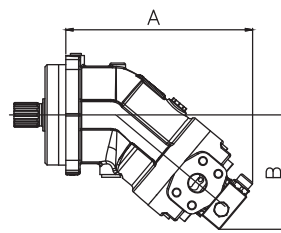

Valvola di lavaggio  
Flushing valve

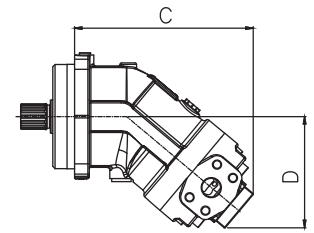

Predisposto per valvola di lavaggio  
Arranged for Flushing Valve

	010 ME 016 ME	020 ME 030 ME	045-055 ME 063 ME	075 ME 090 ME	108 ME 125 ME	160 ME 180 ME	010 SE 016 SE	020 SE 030 SE	055 SE 063 SE	075 SE 090 SE	108 SE 125 SE	160 SE 180 SE
<b>A</b> mm [in]	LM2 /	225 [8.85]	245.7 [9.67]	259.4 [10.21]	294.3 [11.58]	319.6 [12.58]	/	242 [9.52]	269.8 [10.62]	283.5 [11.16]	326.4 [12.85]	351.7 [13.85]
<b>B</b> mm [in]	LM2 /	130 [5.11]	152.8 [6.01]	159.1 [6.26]	179.9 [7.08]	199.1 [7.84]	/	130 [5.11]	152.8 [6.01]	159.1 [6.26]	179.8 [7.08]	199.1 [7.84]
<b>C</b> mm [in]	LM2 /	204 [8.03]	225.7 [8.88]	239.4 [9.42]	274.3 [10.79]	299.6 [11.79]	/	221 [8.70]	204 [8.03]	263.5 [10.37]	306.4 [12.06]	331.7 [13.05]
<b>D</b> mm [in]	LM2 /	120 [4.72]	142.8 [5.62]	149.1 [5.87]	169.9 [6.68]	189.1 [7.44]	/	120 [4.72]	142.8 [5.62]	149.1 [5.87]	169.8 [6.68]	189.1 [7.44]

# VM2

Coperchio distributore  
Port cover

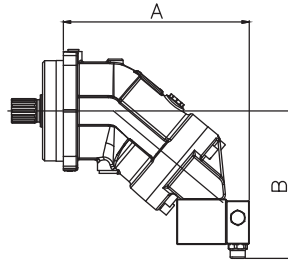

		010 ME 016 ME	020 ME 030 ME	045-055 ME 063 ME	075 ME 090 ME	108 ME 125 ME	160 ME 180 ME	010SE 016 SE	020 ME 030 SE	055 SE 063 SE	075 SE 090 SE	108 SE 125 SE	160 ME 180 SE
<b>A</b> mm [in]	VM2	/	211 [8.31]	239.2 [9.41]	258.8 [10.18]	298.8 [11.76]	313.2 [12.33]	/	229 [9.01]	263.3 [10.36]	282.9 [11.13]	330.8 [13.02]	345.3 [13.59]
<b>B</b> mm [in]	VM2	/	173 [6.81]	193.6 [7.62]	205.2 [8.08]	218.2 [8.59]	231.7 [9.12]	/	173 [6.81]	193.6 [7.62]	205.2 [8.08]	218.2 [8.59]	231.7 [9.12]

# VMD - VMS

Bocche laterali affiancate rotazione oraria o antioraria e valvola unidirezionale  
Lateral ports same side clockwise or counterclockwise and Check valve

## Coperchio posteriore VMD Rear cover VMD

Rotazione oraria  
Clockwise

## Coperchio posteriore VMS Rear cover VMS

Rotazione antioraria  
Counterclockwise

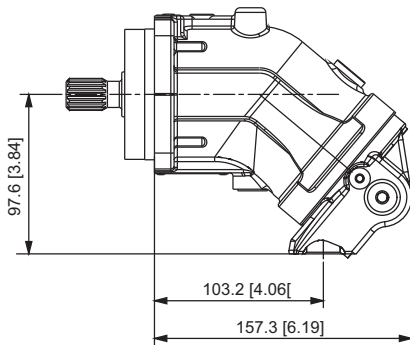

A - B Bocche di alimentazione M22x1.5  
A - B Service ports M22x1.5

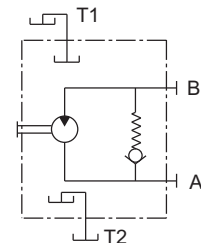
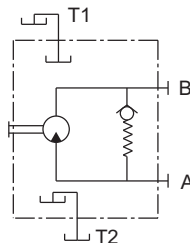
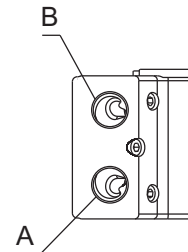
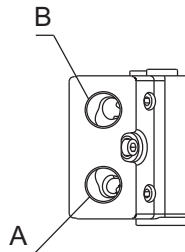

## TAPPI DRENAGGIO INVERTITI DRAIN PLUGS REVERSED

Per la serie SH11C è possibile richiedere la posizione dei tappi del drenaggio invertita rispetto allo Standard. Se si vuole predisporre in questa configurazione è necessario specificare in fase d'ordine la caratteristica "RD" (vedere punto 13 del codice di ordinazione).

For the SH11C is possible to request the drain plug reversed compared to standard. If it is necessary in this configuration, to specify in the purchase order the value "RD" (See position 13 of ordering code).

### VERSIONE STANDARD STANDARD VERSION

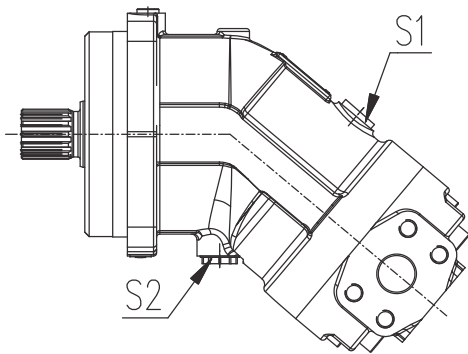

S1 - Tappo in metallo / Metallic plug.  
S2 - Tappo in plastica / Plastic plug.

### VERSIONE "RD" "RD" VERSION

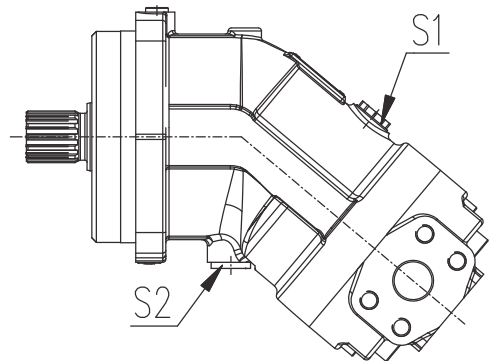

S1 - Tappo in plastica / Plastic plug.  
S2 - Tappo in metallo / Metallic plug.

